

1:	9.7	←
2:	9.4	←
3:	9.6	←
4:	10.0	←
5:	10.5x	↓
6:	8.7	→
7:	10.4x	↑
8:	9.7	→
9:	9.6	↑
10:	8.7	↗
Series		96.3
		96.3

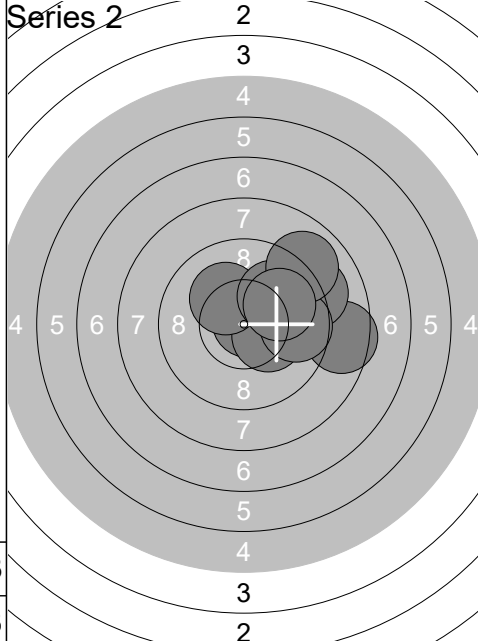

1:	9.7	↗
2:	10.8x	↗
3:	10.3x	↘
4:	8.5	→
5:	9.1	↗
6:	10.1	↖
7:	9.6	→
8:	9.9	↗
9:	8.9	↗
10:	9.9	↗
Series		96.8
		193.1

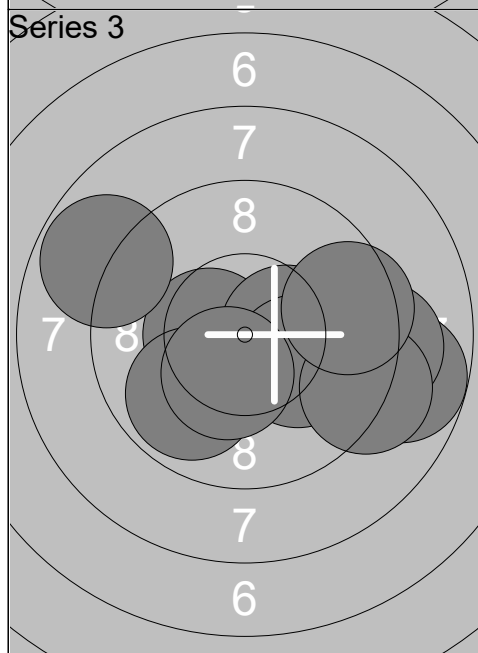

1:	10.4x	←
2:	8.7	→
3:	10.4x	→
4:	8.8	↖
5:	9.1	→
6:	9.9	↘
7:	10.1	↘
8:	10.4x	↘
9:	9.1	↘
10:	9.5	→
Series		96.4
		289.5

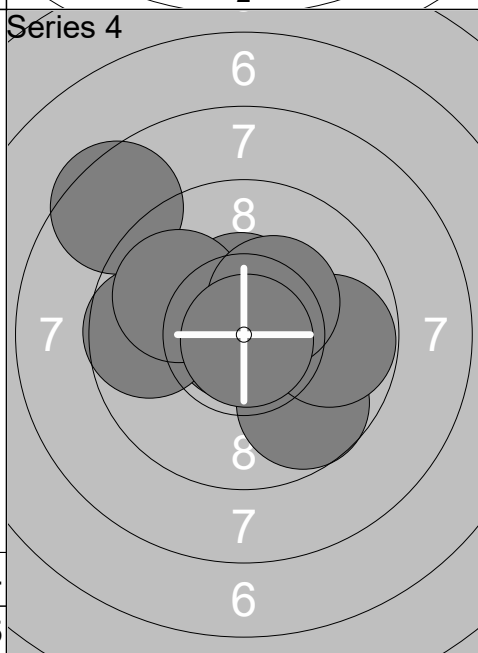

1:	10.8x	←
2:	10.4x	↑
3:	10.1	↘
4:	9.7	↘
5:	9.7	←
6:	9.8	→
7:	8.5	↖
8:	9.9	↖
9:	10.3x	↗
10:	10.8x	↘
Series		100.0
		389.5

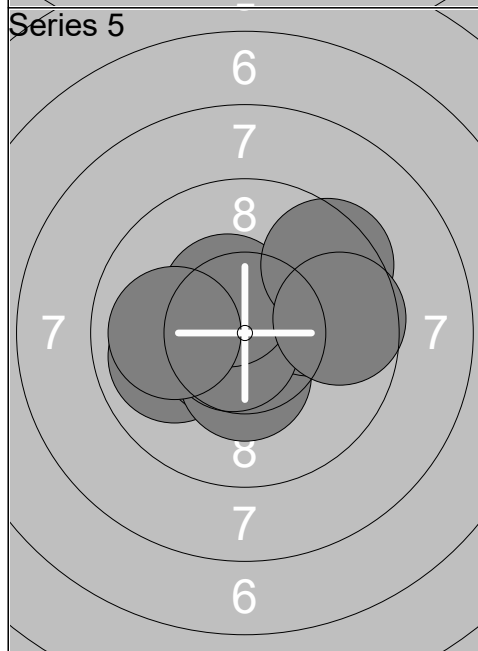

1:	10.8x	↑
2:	9.9	←
3:	10.6x	↘
4:	10.4x	↓
5:	10.0	→
6:	10.7x	↘
7:	10.4x	↖
8:	9.5	↗
9:	10.0	←
10:	9.6	→
Series		101.9
		491.4

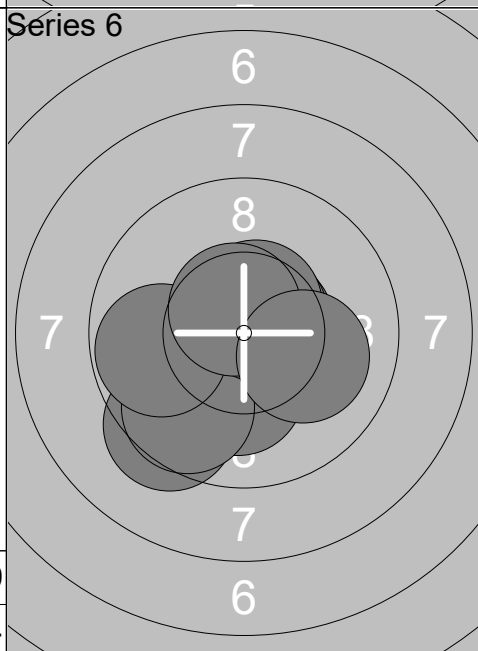

1:	10.2x	↓
2:	10.6x	→
3:	10.0	↖
4:	9.3	↘
5:	9.7	↘
6:	10.6x	↗
7:	10.5x	↑
8:	9.8	←
9:	10.6x	↖
10:	10.0	↘
Series		101.3
		592.7

Relay 1	Lane 8	Jonas Andersen	
-------------------	------------------	-----------------------	--

1 Air Qualification	DEN	M	
---------------------	-----	---	--

19.02.2023	DENMARK OPEN AIR 2023 DAY3	Danmark Open Air 2023	
------------	----------------------------	-----------------------	--

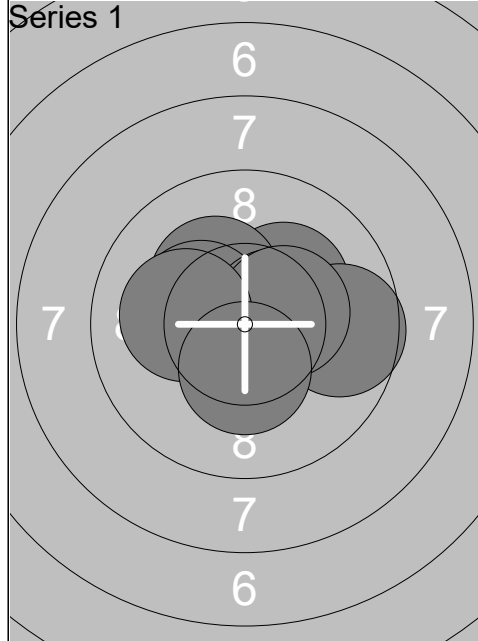

1:	10.2x ↗
2:	10.2x ↖
3:	10.6x ←
4:	10.3x ↖
5:	9.6 →
6:	10.5x →
7:	10.8x ↓
8:	10.4x →
9:	10.1 ←
10:	10.3x ↓
Series	103.0
	103.0

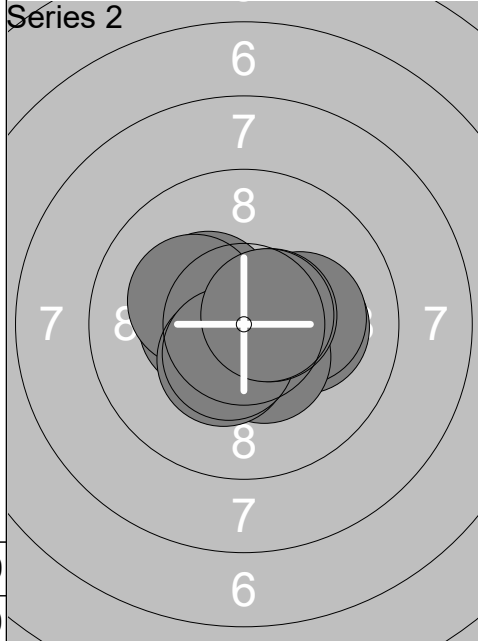

1:	10.1 →
2:	10.4x ←
3:	10.2x →
4:	10.4x ↓
5:	10.3x ↖
6:	10.2x ↖
7:	10.4x ↓
8:	10.5x ↓
9:	10.5x →
10:	10.6x →
Series	103.6
	206.6

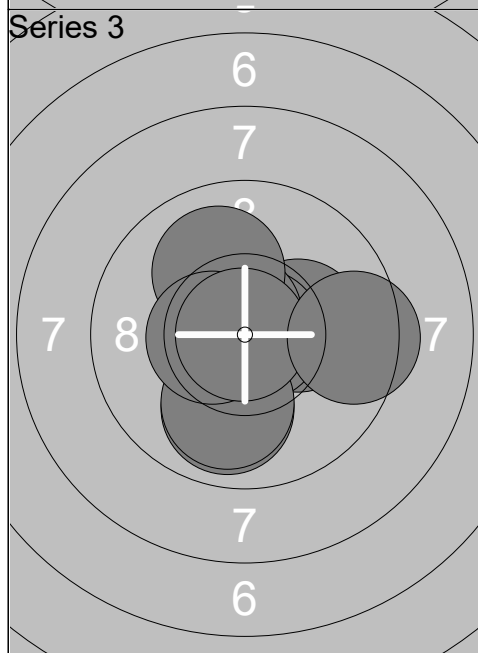

1:	10.8x ↖
2:	9.9 ↓
3:	10.2x →
4:	10.8x →
5:	10.7x ↖
6:	10.0 ↓
7:	10.0 ↖
8:	10.5x ←
9:	10.9x ←
10:	9.5 →
Series	103.3
	309.9

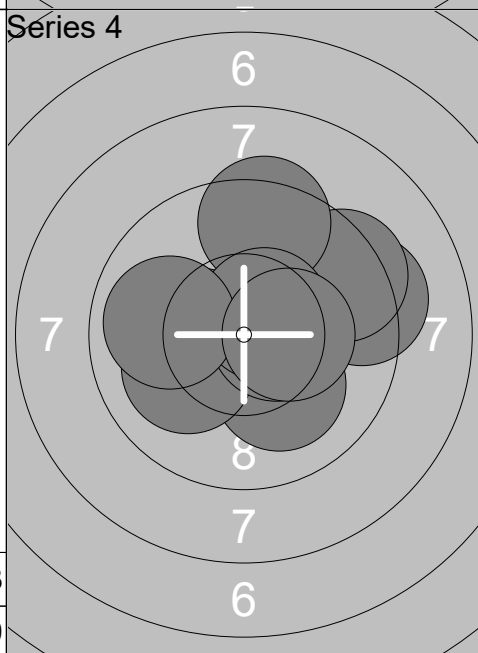

1:	9.2 →
2:	10.3x ←
3:	10.1 ↓
4:	10.1 ←
5:	9.4 ↗
6:	9.4 ↑
7:	10.5x →
8:	10.5x ↗
9:	9.9 ←
10:	10.3x →
Series	99.7
	409.6

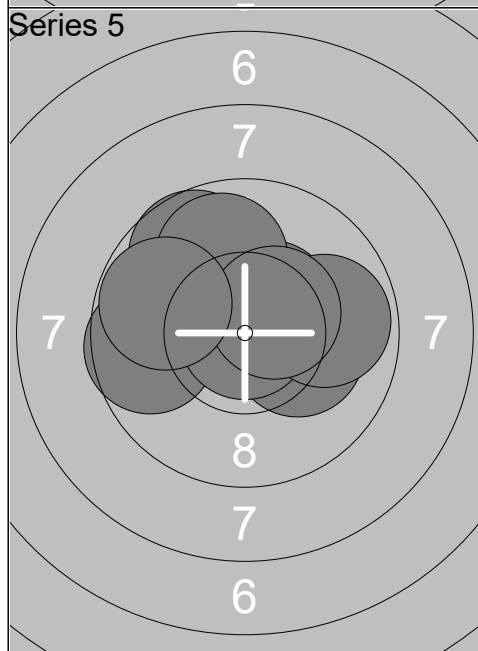

1:	10.4x ↗
2:	9.7 ↖
3:	10.2x ↖
4:	9.6 ←
5:	10.2x →
6:	10.9x
7:	9.8 →
8:	9.9 ↑
9:	10.4x ↗
10:	9.8 ←
Series	100.9
	510.5

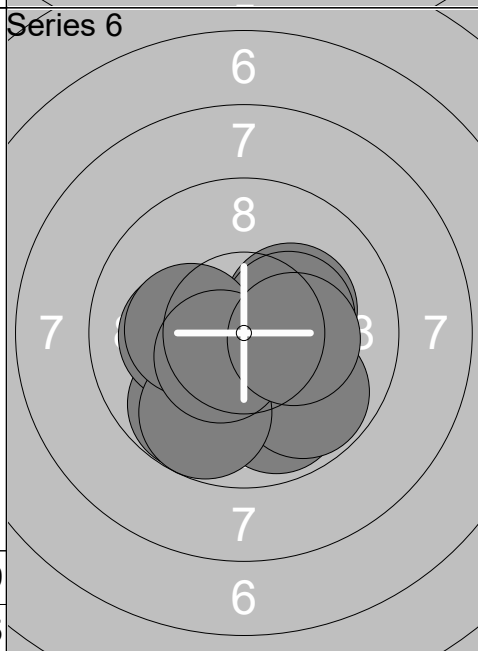

1:	9.7 ↓
2:	9.8 ↓
3:	10.1 ←
4:	10.2x →
5:	9.8 ↓
6:	10.3x →
7:	9.7 ↓
8:	10.2x ←
9:	10.5x ↙
10:	10.2x →
Series	100.5
	611.0

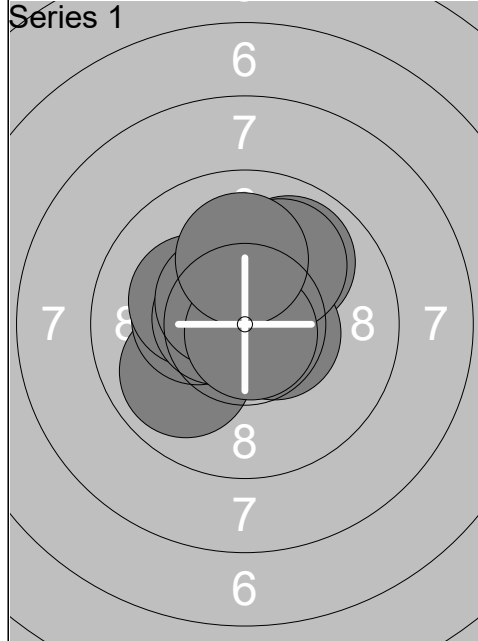

1:	9.9 ↗
2:	9.9 ↙
3:	10.3x ←
4:	10.2x ↙
5:	10.6x ←
6:	10.5x ↗
7:	10.5x →
8:	10.0 ↗
9:	10.8x ↘
10:	10.1 ↑
Series	102.8
	102.8

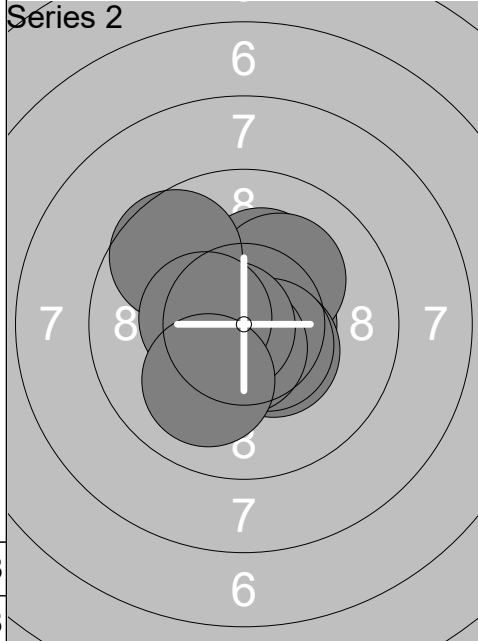

1:	10.6x →
2:	10.2x ↗
3:	10.1 ↗
4:	10.4x ↘
5:	10.5x ↘
6:	10.6x ↓
7:	10.7x ←
8:	9.6 ↙
9:	10.4x ←
10:	10.0 ↓
Series	103.1
	205.9

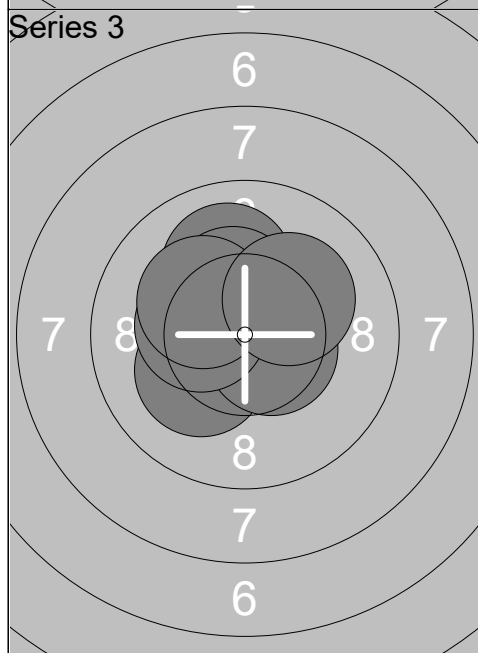

1:	10.0 ↑
2:	10.6x ↙
3:	10.6x ↗
4:	10.2x ↙
5:	10.5x ↗
6:	10.3x ↑
7:	10.5x →
8:	10.3x ←
9:	10.2x ↙
10:	10.1 ↗
Series	103.3
	309.2

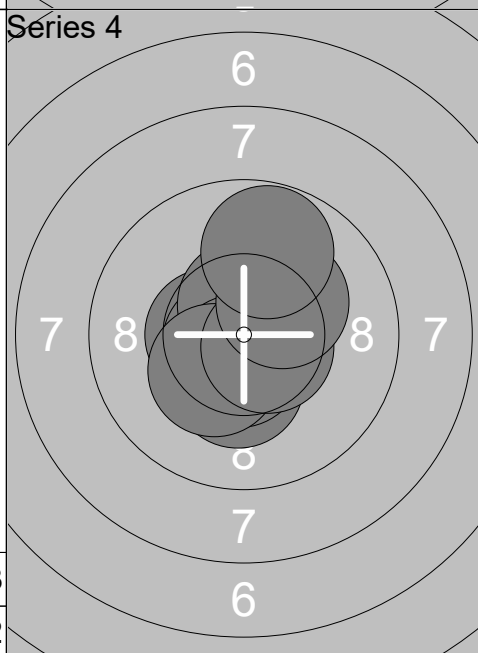

1:	10.3x ↗
2:	10.5x ←
3:	10.3x ↓
4:	10.7x ↙
5:	10.5x ↑
6:	10.6x ↓
7:	10.3x ↙
8:	10.6x →
9:	10.2x ↗
10:	9.7 ↑
Series	103.7
	412.9

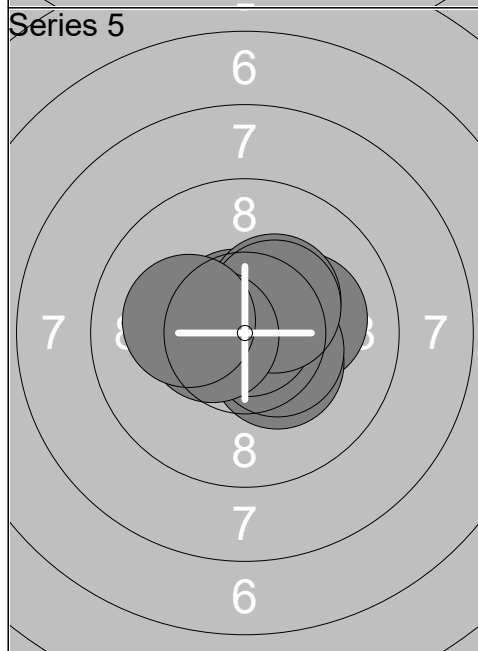

1:	10.1 →
2:	10.7x ↗
3:	10.3x ↗
4:	10.3x ↘
5:	10.9x ↑
6:	10.4x →
7:	10.9x ↗
8:	10.4x ↗
9:	10.5x ←
10:	10.2x ←
Series	104.7
	517.6

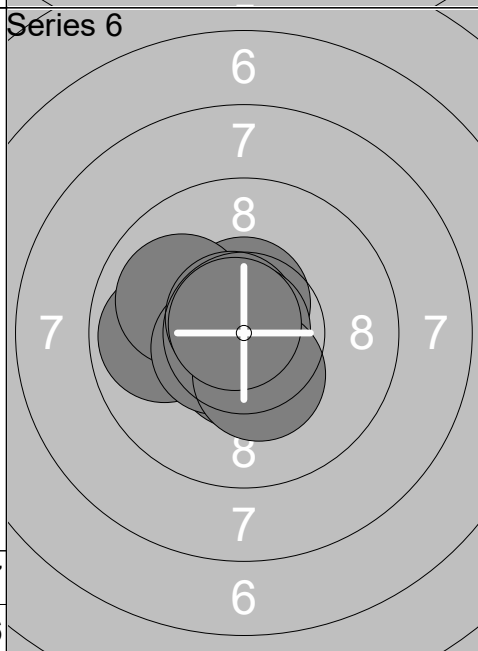

1:	10.5x ←
2:	10.5x ↓
3:	9.8 ←
4:	10.5x ↑
5:	10.0 ↙
6:	10.5x ↙
7:	10.7x ↙
8:	10.9x ↑
9:	10.3x ↓
10:	10.7x ↙
Series	104.4
	622.0

Relay	Lane	Jens Frimann		
1 Air Qualification	DEN	M		
19.02.2023	DENMARK OPEN AIR 2023 DAY3	Danmark Open Air 2023		
Series 1	1: 10.8x → 2: 9.8 → 3: 9.7 → 4: 10.4x ← 5: 10.3x ↗ 6: 9.7 ← 7: 10.6x ↗ 8: 10.2x → 9: 10.5x ↘ 10: 10.4x ← Series 102.4 102.4	Series 2	1: 10.2x ↘ 2: 10.0 → 3: 10.2x ↗ 4: 10.2x ↘ 5: 10.6x → 6: 10.6x ← 7: 10.8x ↘ 8: 10.4x ↗ 9: 9.8 ↘ 10: 10.7x ↘ Series 103.5 205.9	
Series 3	1: 10.4x → 2: 9.7 ↘ 3: 10.0 ↘ 4: 9.9 ← 5: 10.0 ↘ 6: 10.3x ← 7: 9.8 ↙ 8: 9.8 ↘ 9: 9.8 ↘ 10: 10.8x ← Series 100.5 306.4	Series 4	1: 10.0 ↘ 2: 10.2x ← 3: 10.4x ↘ 4: 10.6x → 5: 9.9 ↗ 6: 10.5x → 7: 9.9 ← 8: 9.7 ← 9: 9.5 ↗ 10: 9.7 ↗ Series 100.4 406.8	
Series 5	1: 10.1 → 2: 9.1 ↖ 3: 9.3 ↗ 4: 9.7 ↗ 5: 9.9 ← 6: 9.6 ↘ 7: 10.0 → 8: 10.6x ↗ 9: 10.3x ↖ 10: 9.9 ↗ Series 98.5 505.3	Series 6	1: 10.1 ↗ 2: 10.0 ↘ 3: 10.0 ↗ 4: 10.1 → 5: 10.5x ↘ 6: 9.5 → 7: 10.5x ← 8: 10.0 → 9: 10.7x → 10: 10.3x ↘ Series 101.7 607.0	

Relay	Lane	Anders Henricsson	
1 Air Qualification	SWE	M	
19.02.2023	DENMARK OPEN AIR 2023 DAY3	Danmark Open Air 2023	
Series 1	1: 9.9 ↖ 2: 10.6x ↘ 3: 10.6x ↗ 4: 10.5x ↙ 5: 9.8 ↓ 6: 10.7x ↘ 7: 10.7x ↑ 8: 10.2x → 9: 10.5x ↓ 10: 10.0 ↗ Series 103.5 103.5	Series 2	1: 10.4x ↓ 2: 9.7 ↘ 3: 10.7x ↗ 4: 10.5x ↗ 5: 10.2x ↓ 6: 10.0 ↗ 7: 10.2x ↖ 8: 10.3x ↖ 9: 9.2 ← 10: 10.2x ↑ Series 101.4 204.9
Series 3	1: 9.8 ↗ 2: 10.7x ↓ 3: 10.7x ↙ 4: 10.5x ↖ 5: 10.4x ↘ 6: 10.7x ↙ 7: 10.8x ↖ 8: 10.9x → 9: 10.4x ↗ 10: 10.7x ↙ Series 105.6 310.5	Series 4	1: 10.2x ↑ 2: 10.6x ↘ 3: 10.4x → 4: 10.3x ↖ 5: 10.2x ↙ 6: 10.5x ↗ 7: 9.9 → 8: 10.1 ← 9: 10.1 ↑ 10: 10.3x ↘ Series 102.6 413.1
Series 5	1: 10.6x ↖ 2: 10.0 → 3: 9.9 ↘ 4: 10.7x ↑ 5: 10.9x → 6: 10.8x ↙ 7: 10.0 ↓ 8: 10.3x ↓ 9: 10.6x ↓ 10: 10.6x ↓ Series 104.4 517.5	Series 6	1: 10.6x ↙ 2: 10.8x ↙ 3: 10.4x ↘ 4: 10.0 ↗ 5: 10.3x ↙ 6: 10.8x ↓ 7: 10.5x ↘ 8: 10.4x ↖ 9: 10.6x ↖ 10: 10.7x → Series 105.1 622.6

Relay	Lane	Viktor Klemmedsson	
1 Air Qualification	SWE	M	
19.02.2023	DENMARK OPEN AIR 2023 DAY3	Danmark Open Air 2023	
Series 1	1: 10.9x ↓ 2: 10.2x ↙ 3: 9.9 ↗ 4: 10.3x ↙ 5: 10.2x → 6: 10.6x ↗ 7: 10.5x ↗ 8: 10.1 ↗ 9: 10.2x ↙ 10: 10.5x ↘ Series 103.4 103.4	Series 2	1: 10.7x ↖ 2: 10.4x → 3: 10.2x ↙ 4: 10.1 ↗ 5: 10.6x ↘ 6: 10.0 ↙ 7: 10.0 ↙ 8: 10.1 ↙ 9: 10.3x ↘ 10: 10.1 ↓ Series 102.5 205.9
Series 3	1: 10.1 ↘ 2: 10.5x → 3: 10.4x → 4: 10.5x ↗ 5: 10.7x ↘ 6: 10.2x ↙ 7: 10.6x ↙ 8: 10.5x ↙ 9: 10.5x ↙ 10: 10.4x → Series 104.4 310.3	Series 4	1: 10.1 ↘ 2: 10.7x ↘ 3: 10.4x → 4: 10.3x ↘ 5: 10.0 ↙ 6: 10.7x ↓ 7: 9.8 → 8: 10.6x ↗ 9: 10.4x ↗ 10: 9.8 → Series 102.8 413.1
Series 5	1: 10.6x → 2: 10.5x ↙ 3: 10.8x ↘ 4: 10.8x → 5: 10.3x ↙ 6: 10.3x → 7: 10.0 ↘ 8: 9.4 → 9: 10.6x ↘ 10: 10.6x ↙ Series 103.9 517.0	Series 6	1: 10.4x ↗ 2: 10.1 ↓ 3: 10.8x ↓ 4: 10.4x ↙ 5: 10.3x ↙ 6: 10.5x → 7: 10.1 ↗ 8: 9.9 ↓ 9: 10.4x ↙ 10: 9.9 ↙ Series 102.8 619.8

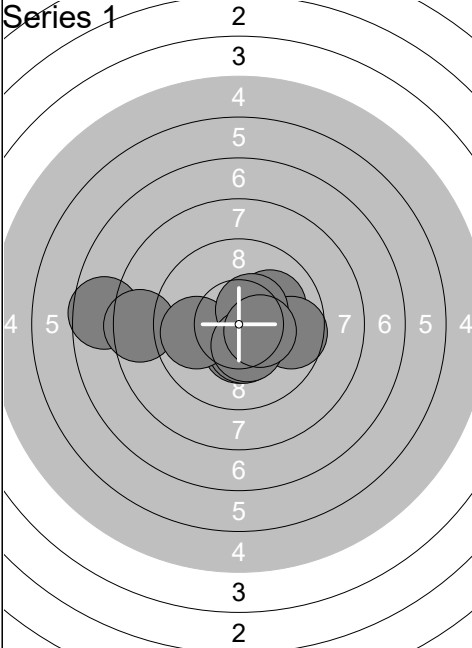
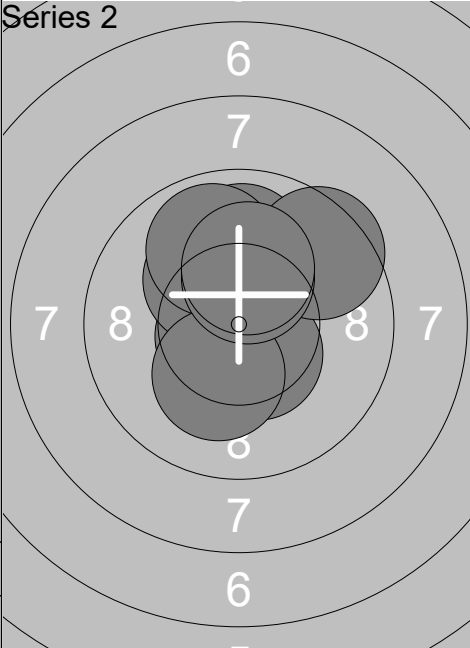
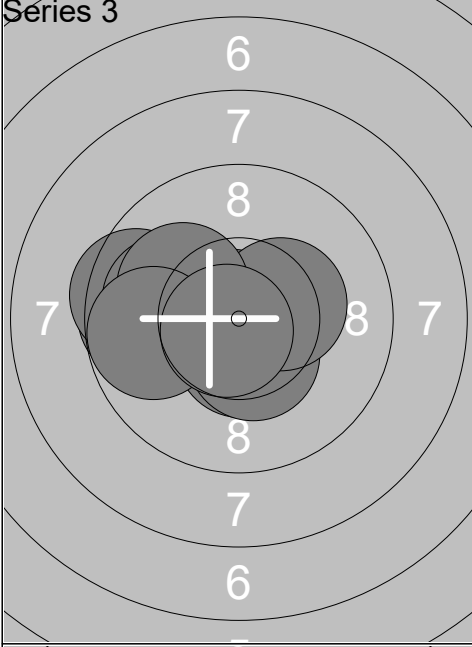
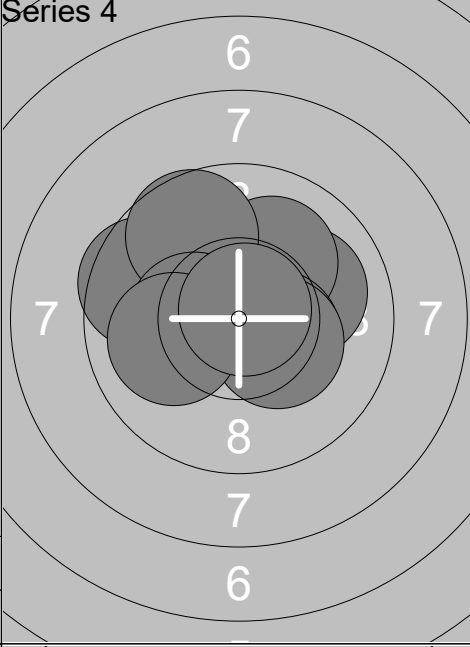
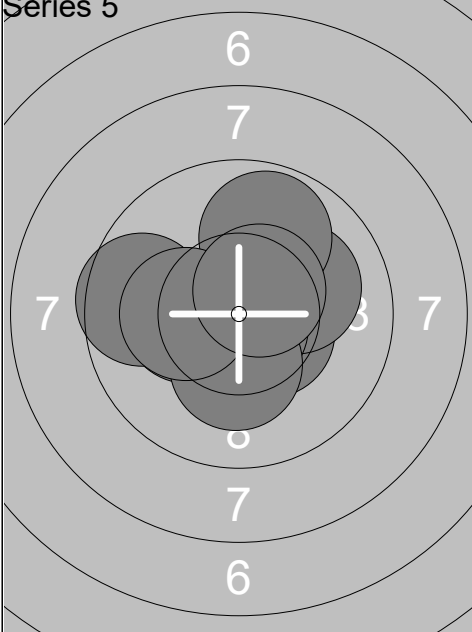
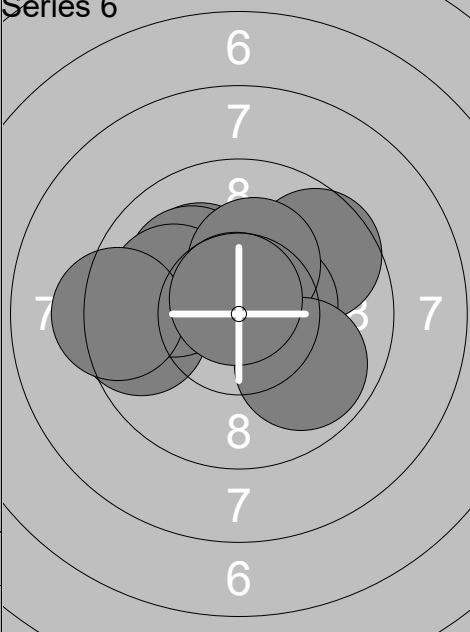
Relay	Lane	Steffen Koefoed	
1	15		
1 Air Qualification		DEN	M
19.02.2023		DENMARK OPEN AIR 2023 DAY3	Danmark Open Air 2023
Series 1		1: 10.4x ↓ 2: 7.6 ← 3: 8.5 ← 4: 10.0 ↗ 5: 10.3x ↓ 6: 9.9 ← 7: 9.6 → 8: 10.4x ↗ 9: 10.3x ↓ 10: 10.4x → Series 97.4 97.4	Series 2  1: 10.3x ↑ 2: 10.6x ↙ 3: 10.4x ↘ 4: 9.9 ↑ 5: 10.2x ↖ 6: 9.5 ↗ 7: 10.2x ↘ 8: 9.8 ↑ 9: 10.3x ↑ 10: 10.2x ↑ Series 101.4 198.8
Series 3		1: 10.8x ↙ 2: 9.6 ← 3: 10.5x ↓ 4: 9.5 ← 5: 10.4x ↓ 6: 9.9 ← 7: 10.3x → 8: 10.1 ← 9: 9.8 ← 10: 10.7x ↘ Series 101.6 300.4	Series 4  1: 10.6x ↖ 2: 10.0 → 3: 9.5 ← 4: 10.0 ↗ 5: 10.4x → 6: 9.6 ↖ 7: 10.3x → 8: 10.3x ← 9: 10.0 ← 10: 10.8x ↗ Series 101.5 401.9
Series 5		1: 10.7x ↓ 2: 10.5x → 3: 10.1 → 4: 10.8x ↓ 5: 10.2x ← 6: 10.3x ↓ 7: 9.6 ← 8: 9.8 ↑ 9: 10.2x ← 10: 10.5x ↗ Series 102.7 504.6	Series 6  1: 9.6 ← 2: 9.6 ↗ 3: 10.1 ↖ 4: 10.1 ↖ 5: 10.5x → 6: 10.0 ← 7: 9.3 ← 8: 10.2x ↑ 9: 9.8 ↘ 10: 10.7x ↑ Series 99.9 604.5

Relay	Lane	Timothée Vedel		
1 Air Qualification	FRA	M		
19.02.2023	DENMARK OPEN AIR 2023 DAY3	Danmark Open Air 2023		
Series 1	1: 10.1 ← 2: 10.6x ↖ 3: 10.5x ↗ 4: 10.2x ↖ 5: 10.0 ↗ 6: 10.4x → 7: 9.3 ↘ 8: 10.5x → 9: 10.3x → 10: 10.9x ↘ Series 102.8 102.8	Series 2	1: 10.4x → 2: 10.3x ↗ 3: 10.6x ↑ 4: 10.2x ← 5: 10.4x ↘ 6: 10.5x ↙ 7: 10.4x ↓ 8: 10.3x ↙ 9: 10.4x ↙ 10: 10.4x ↗ Series 103.9 206.7	
Series 3	1: 10.5x → 2: 10.2x ← 3: 10.0 ↗ 4: 10.4x ↖ 5: 10.6x ↘ 6: 10.4x ← 7: 10.7x ↗ 8: 10.2x → 9: 10.7x → 10: 10.7x ↑ Series 104.4 311.1	Series 4	1: 10.7x ↗ 2: 10.5x ← 3: 10.7x ↖ 4: 10.1 ↓ 5: 10.8x → 6: 10.5x → 7: 10.7x → 8: 10.7x ↑ 9: 10.2x ↑ 10: 10.6x ↘ Series 105.5 416.6	
Series 5	1: 10.1 ← 2: 10.0 ↘ 3: 10.7x ↖ 4: 10.4x ↑ 5: 10.1 ↗ 6: 10.7x → 7: 10.1 → 8: 9.9 ↗ 9: 9.9 ↗ 10: 10.3x ↘ Series 102.2 518.8	Series 6	1: 10.5x → 2: 10.1 → 3: 10.2x → 4: 10.5x ↑ 5: 10.4x ↖ 6: 10.6x ← 7: 10.2x ↘ 8: 10.7x ↑ 9: 10.5x ↖ 10: 10.2x ↑ Series 103.9 622.7	

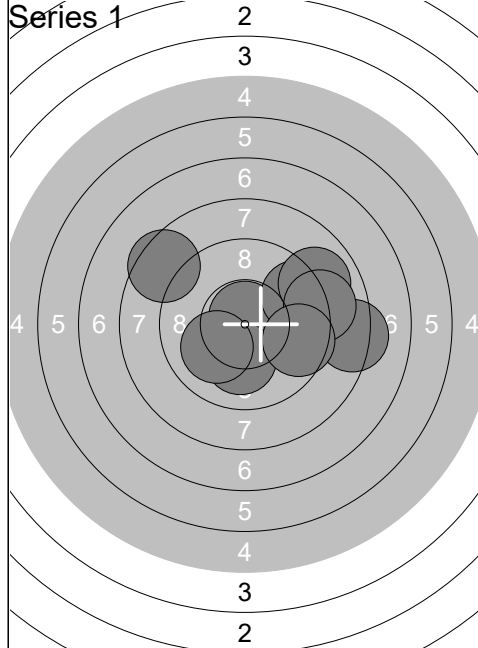

1:	8.3	→
2:	8.5	↖
3:	10.4x	→
4:	10.8x	↑
5:	9.5	→
6:	10.1	↓
7:	10.0	↙
8:	8.9	→
9:	9.0	→
10:	9.6	→
Series	95.1	
	95.1	

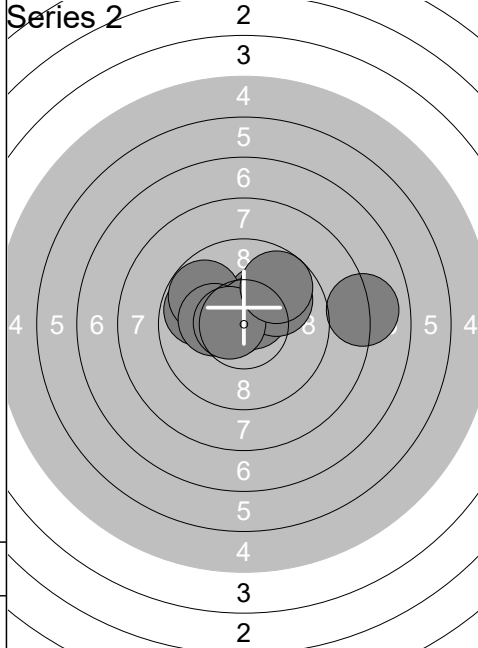

1:	8.0	→
2:	9.8	↖
3:	10.7x	↖
4:	10.2x	↗
5:	9.7	↖
6:	10.6x	↗
7:	10.2x	↖
8:	9.9	↗
9:	10.6x	↖
10:	9.7	↗
Series	99.4	
	194.5	

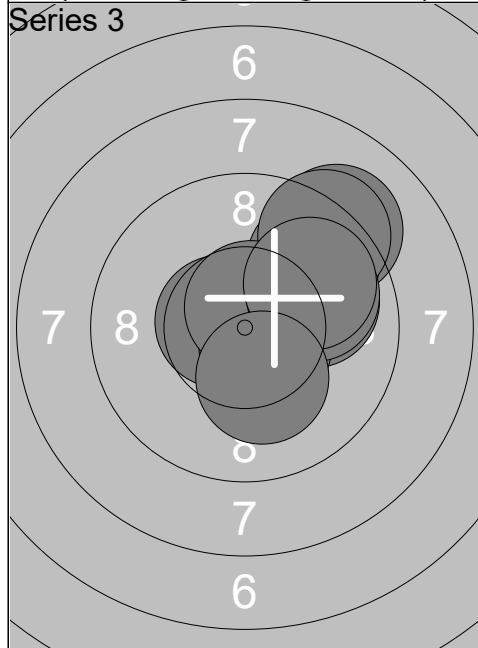

1:	9.1	↗
2:	10.6x	↖
3:	9.7	↗
4:	9.3	↗
5:	9.9	→
6:	10.5x	↘
7:	10.6x	↑
8:	9.9	→
9:	9.9	↗
10:	10.2x	↓
Series	99.7	
	294.2	

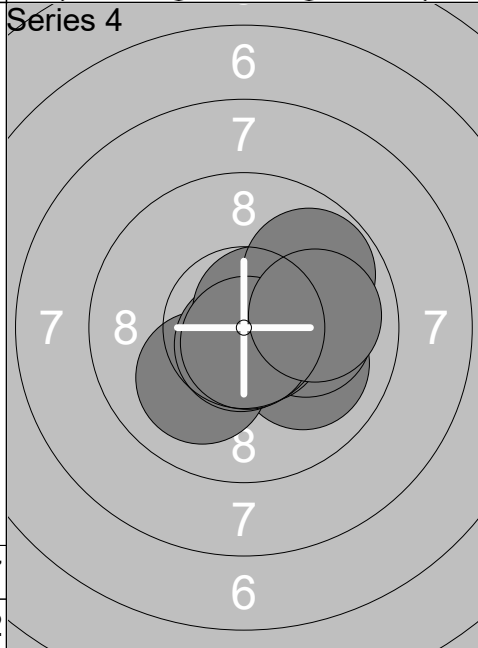

1:	10.0	↘
2:	10.1	→
3:	10.7x	↘
4:	10.3x	→
5:	10.0	↓
6:	10.7x	↓
7:	10.6x	↗
8:	9.8	↗
9:	10.7x	↓
10:	10.0	→
Series	102.9	
	397.1	

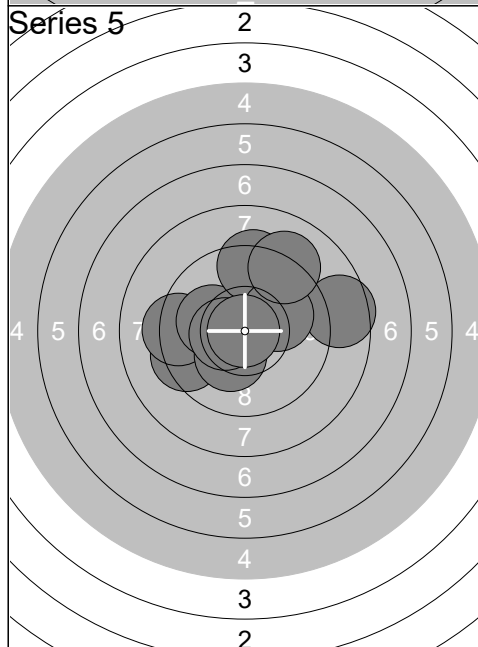

1:	9.4	↖
2:	9.3	↖
3:	10.1	↖
4:	10.2x	↓
5:	10.4x	↖
6:	8.6	→
7:	9.3	↑
8:	10.0	↗
9:	9.1	↗
10:	10.9x	↖
Series	97.3	
	494.4	

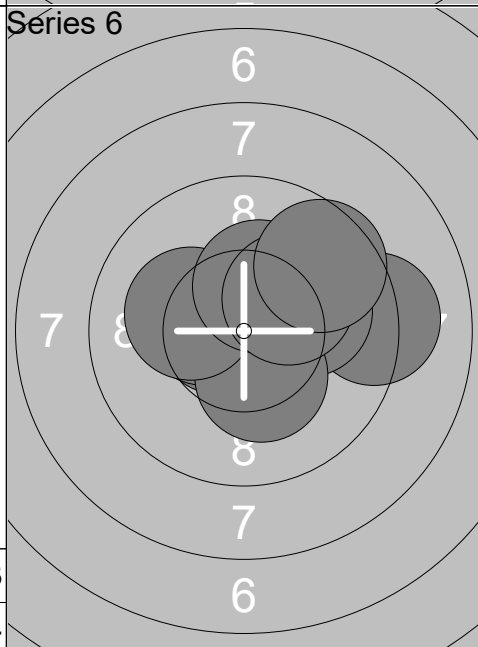

1:	10.6x	↖
2:	10.4x	↗
3:	9.2	→
4:	10.4x	↖
5:	10.0	→
6:	10.3x	↓
7:	10.2x	↖
8:	10.3x	↑
9:	10.2x	↗
10:	9.6	↗
Series	101.2	
	595.6	

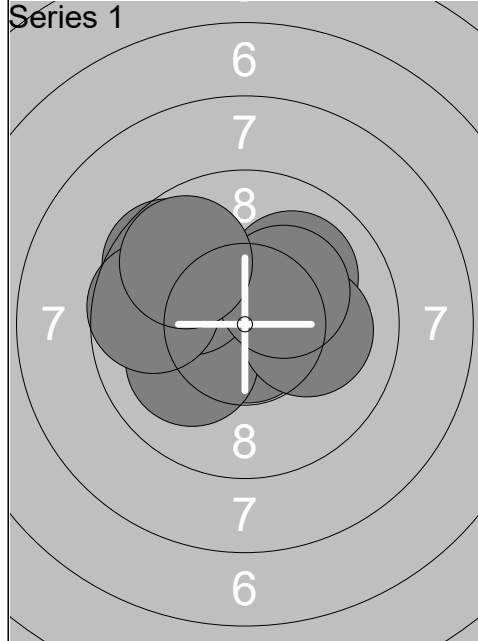

1:	10.3x ↙
2:	10.8x ↓
3:	10.0 ↗
4:	10.1 ↙
5:	10.1 →
6:	10.0 ↙
7:	10.2x ↗
8:	9.6 ↙
9:	9.7 ←
10:	9.8 ↙
Series	100.6
	100.6

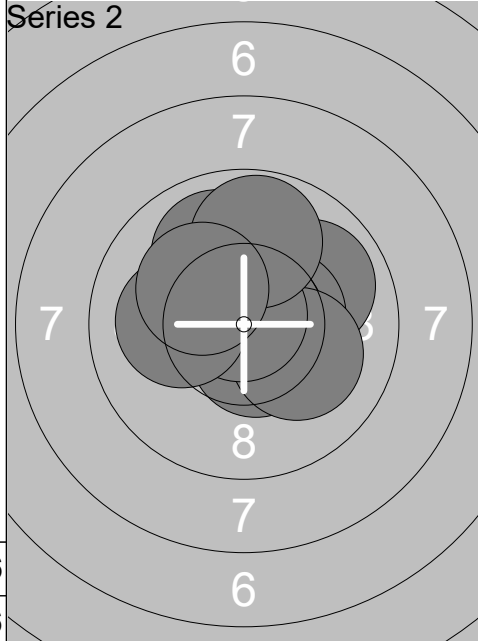

1:	9.9 ↗
2:	10.4x →
3:	10.7x →
4:	9.9 ↑
5:	10.5x ↓
6:	10.1 ↘
7:	10.8x ↑
8:	10.1 ←
9:	9.8 ↑
10:	10.2x ↙
Series	102.4
	203.0

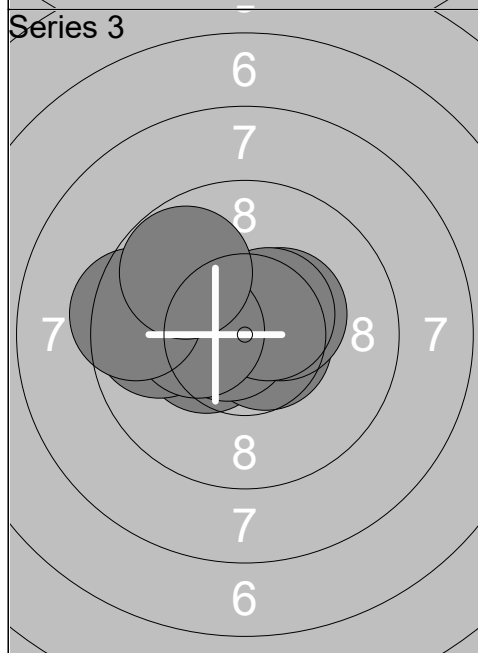

1:	10.6x ←
2:	10.4x ←
3:	10.6x →
4:	10.4x ↗
5:	9.8 ←
6:	10.7x ←
7:	10.5x ↗
8:	10.3x ←
9:	9.4 ←
10:	9.8 ↙
Series	102.5
	305.5

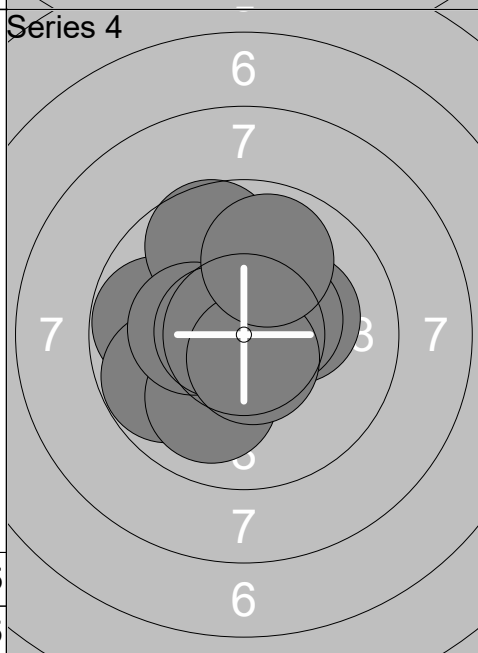

1:	9.8 ←
2:	10.2x →
3:	9.6 ↑
4:	10.4x →
5:	9.7 ↙
6:	10.0 ↓
7:	10.2x ←
8:	10.6x ←
9:	10.6x ↓
10:	9.9 ↑
Series	101.0
	406.5

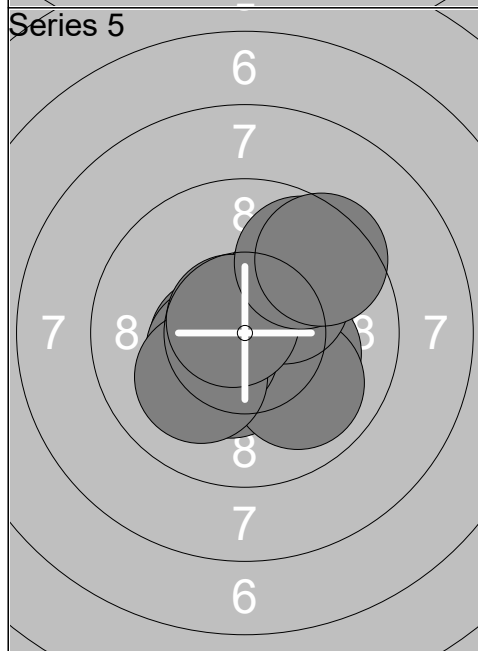

1:	10.2x →
2:	10.4x ↓
3:	9.9 ↓
4:	10.2x ↗
5:	10.5x ←
6:	10.4x ↙
7:	10.1 ↙
8:	10.7x ↙
9:	9.7 ↗
10:	9.5 ↗
Series	101.6
	508.1

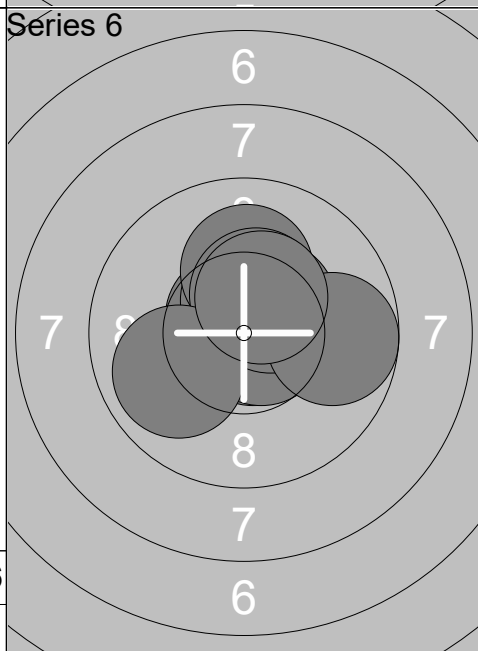

1:	10.7x ↙
2:	10.8x ↘
3:	10.5x ↑
4:	10.1 ↑
5:	10.7x →
6:	10.4x ↑
7:	10.4x ↗
8:	9.7 →
9:	9.9 ↙
10:	10.4x ↗
Series	103.6
	611.7

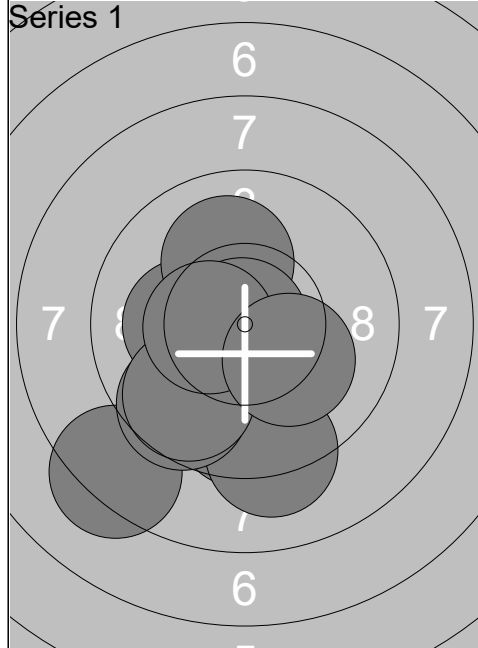

1:	10.2x←
2:	10.0 ↑
3:	9.6 ↓
4:	10.9x←
5:	9.2 ↓
6:	8.3 ↓
7:	9.6 ↓
8:	9.7 ↓
9:	10.5x←
10:	10.2x↘
Series	98.2
	98.2

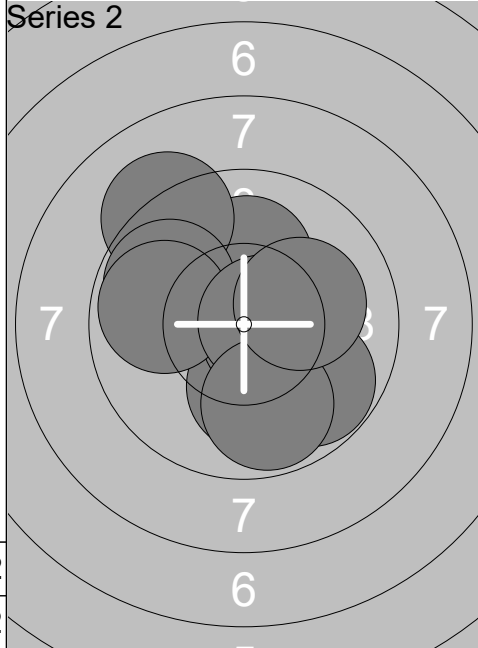

1:	10.1 ↑
2:	10.1 ↓
3:	9.1 ↗
4:	10.6x→
5:	9.8 ↖
6:	9.8 ←
7:	10.6x→
8:	9.8 ↘
9:	9.8 ↓
10:	10.1 →
Series	99.8
	198.0

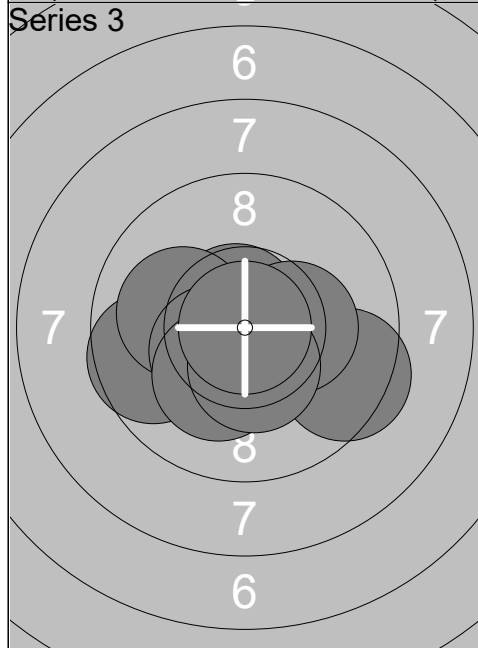

1:	10.1 ←
2:	9.6 ←
3:	9.4 →
4:	10.7x↗
5:	10.1 ←
6:	10.4x↙
7:	10.3x→
8:	10.2x↘
9:	10.4x↓
10:	10.9x
Series	102.1
	300.1

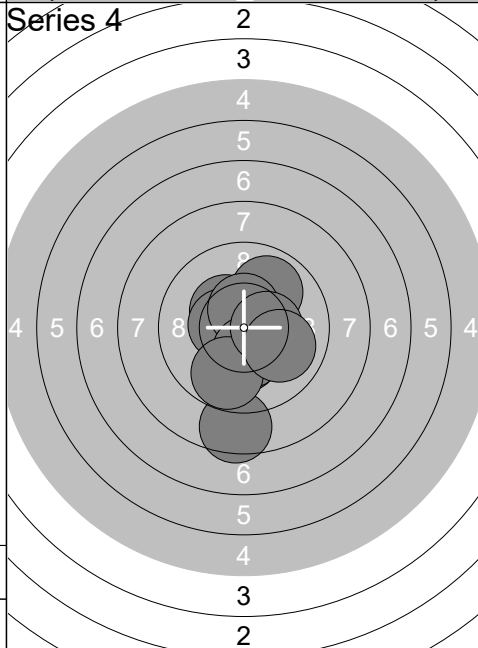

1:	8.5 ↓
2:	10.3x↖
3:	10.3x↓
4:	9.9 ↗
5:	10.5x←
6:	10.5x↑
7:	10.3x↓
8:	9.7 ↓
9:	10.4x→
10:	9.9 ↘
Series	100.3
	400.4

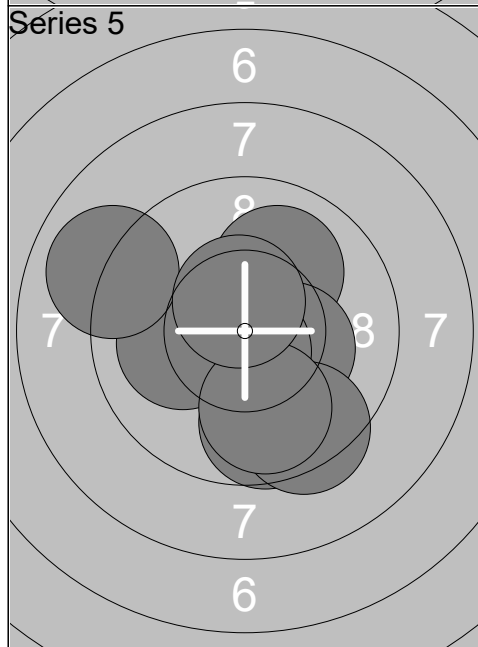

1:	10.5x←
2:	10.0 ↗
3:	9.7 ↓
4:	10.3x→
5:	10.7x↓
6:	9.4 ↓
7:	10.1 ←
8:	8.9 ↖
9:	9.9 ↓
10:	10.5x↑
Series	100.0
	500.4

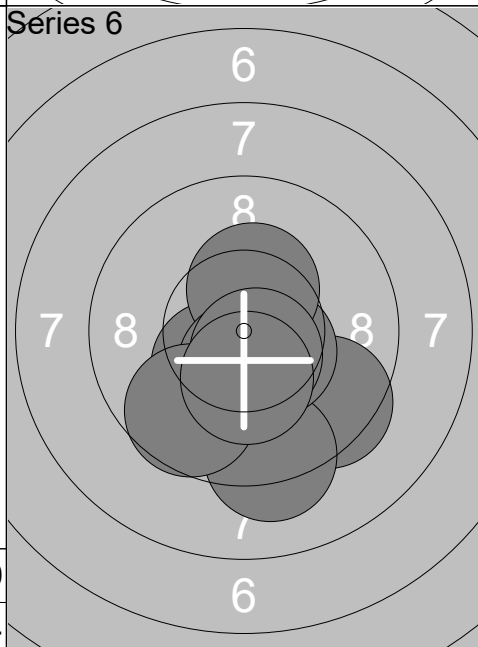

1:	9.6 ↓
2:	10.3x↙
3:	9.5 ↘
4:	9.2 ↓
5:	10.5x↘
6:	10.3x↑
7:	10.5x↓
8:	9.6 ↙
9:	10.5x↓
10:	10.3x↓
Series	100.3
	600.7

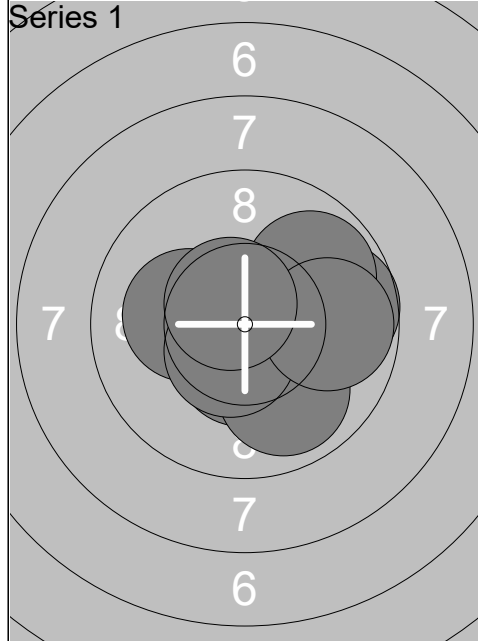

1:	10.8x ←
2:	10.2x ←
3:	10.4x ↓
4:	9.7 →
5:	10.1 ↓
6:	9.9 ↓
7:	10.5x ↓
8:	9.8 ↗
9:	9.8 →
10:	10.6x ↖
Series	101.8
	101.8

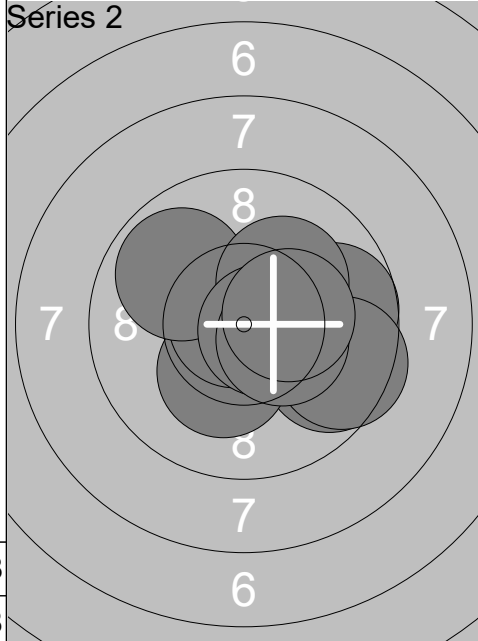

1:	9.6 →
2:	10.2x ↓
3:	9.7 →
4:	10.8x ←
5:	9.8 ↖
6:	10.2x ↗
7:	10.6x →
8:	9.5 →
9:	10.4x →
10:	10.3x →
Series	101.1
	202.9

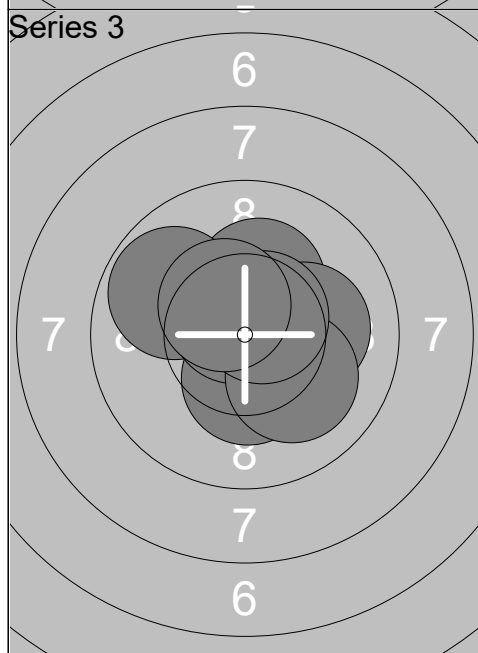

1:	10.8x →
2:	10.3x ↓
3:	10.5x ↖
4:	10.2x ↗
5:	9.8 ↖
6:	10.7x ↖
7:	10.1 →
8:	10.1 ↓
9:	10.6x ↗
10:	10.4x ↖
Series	103.5
	306.4

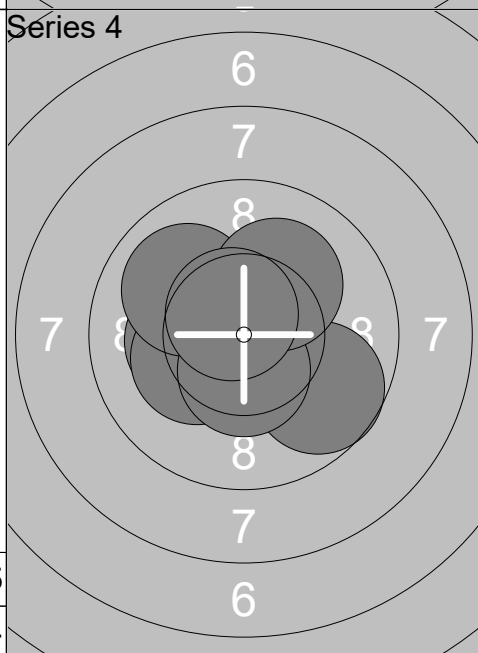

1:	10.2x ←
2:	10.5x ↓
3:	10.8x →
4:	10.2x ←
5:	10.8x ↗
6:	9.7 →
7:	9.9 ↖
8:	10.4x ↓
9:	10.1 ↗
10:	10.6x ↖
Series	103.2
	409.6

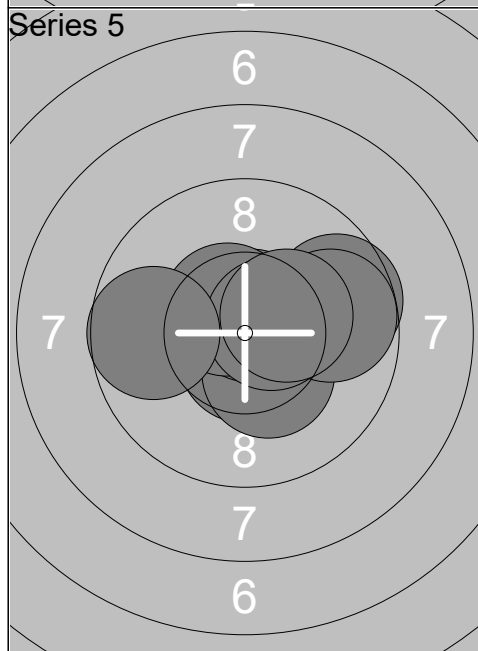

1:	9.6 →
2:	10.6x ↓
3:	10.6x ↖
4:	10.3x ↓
5:	9.8 →
6:	10.7x ↗
7:	10.5x ↖
8:	10.6x →
9:	10.3x →
10:	9.7 ←
Series	102.7
	512.3

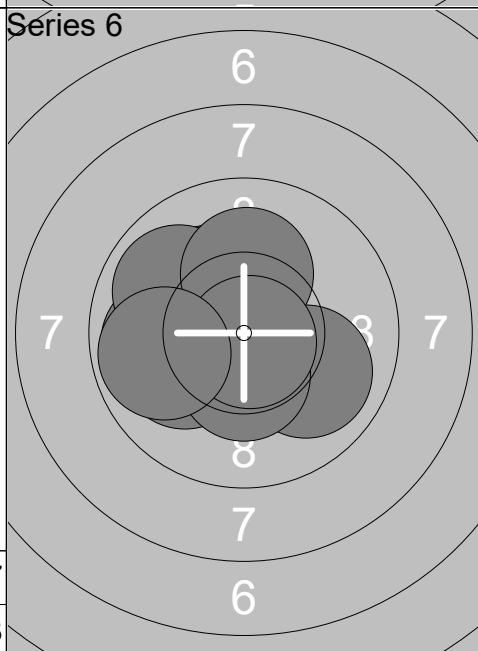

1:	10.6x ←
2:	10.1 ←
3:	9.9 →
4:	9.9 ←
5:	10.4x ↓
6:	10.2x ↖
7:	9.9 ↖
8:	10.1 ↑
9:	10.8x ↓
10:	9.8 ←
Series	101.7
	614.0

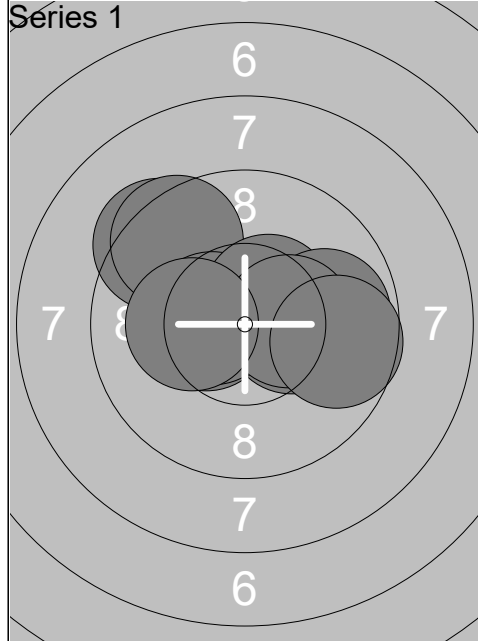

1:	10.3x	→
2:	9.3	↖
3:	9.5	↗
4:	10.4x	←
5:	10.5x	←
6:	10.5x	↗
7:	9.8	→
8:	10.3x	→
9:	9.7	→
10:	10.2x	←
Series	100.5	
	100.5	

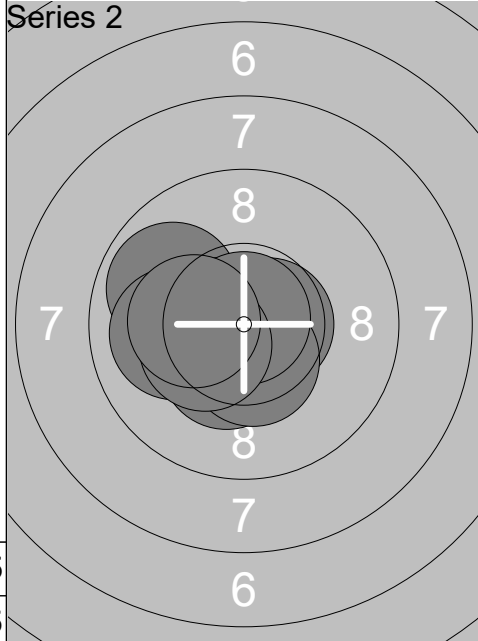

1:	9.8	↖
2:	10.4x	↘
3:	10.0	←
4:	10.3x	←
5:	10.6x	→
6:	10.4x	↘
7:	10.5x	←
8:	10.8x	↑
9:	10.3x	↙
10:	10.3x	←
Series	103.4	
	203.9	

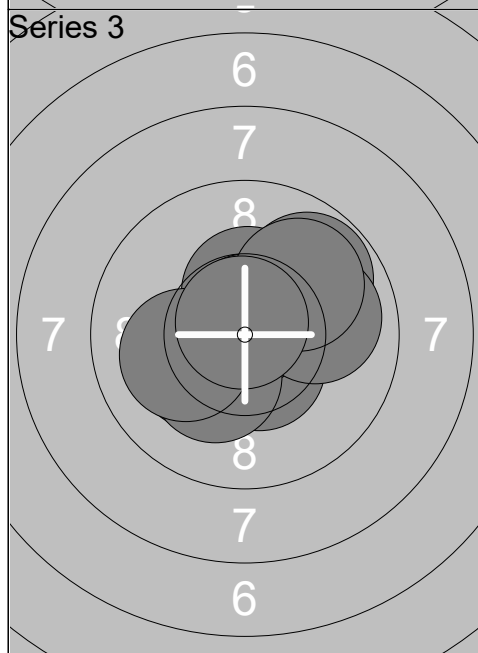

1:	9.8	↗
2:	10.4x	↑
3:	10.5x	↘
4:	10.7x	↑
5:	10.2x	↙
6:	10.2x	↘
7:	9.9	→
8:	10.1	←
9:	9.9	↗
10:	10.8x	↑
Series	102.5	
	306.4	

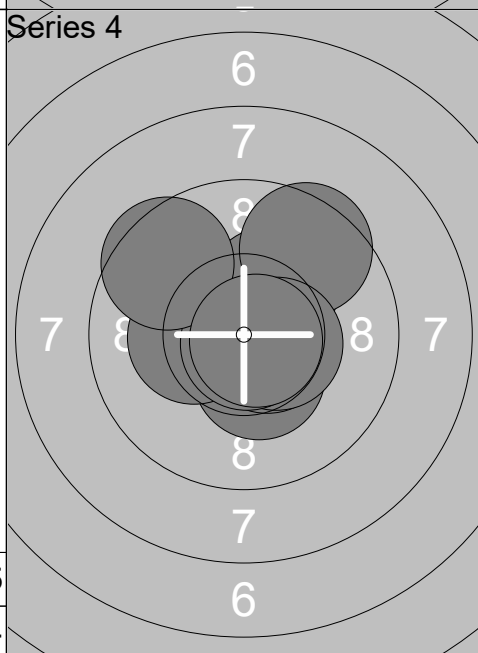

1:	10.3x	↗
2:	9.5	↗
3:	10.6x	↘
4:	10.4x	↘
5:	10.6x	→
6:	10.5x	→
7:	10.2x	←
8:	10.8x	↘
9:	9.5	↖
10:	10.8x	→
Series	103.2	
	409.6	

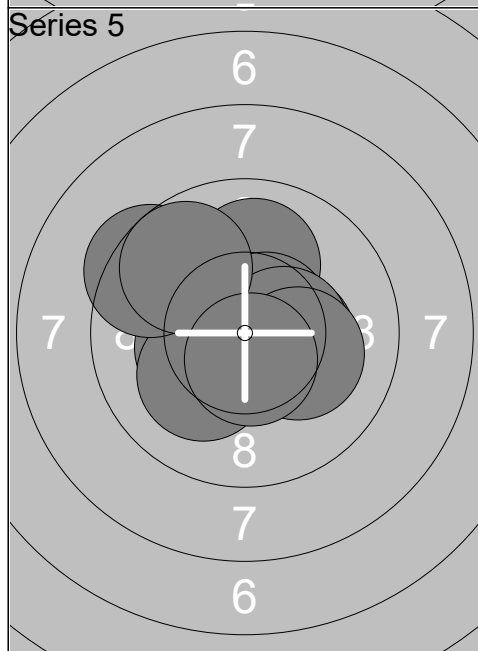

1:	10.3x	←
2:	10.0	↑
3:	10.3x	→
4:	10.1	↘
5:	10.6x	↗
6:	10.4x	→
7:	10.2x	→
8:	9.4	↖
9:	9.7	↗
10:	10.6x	↘
Series	101.6	
	511.2	

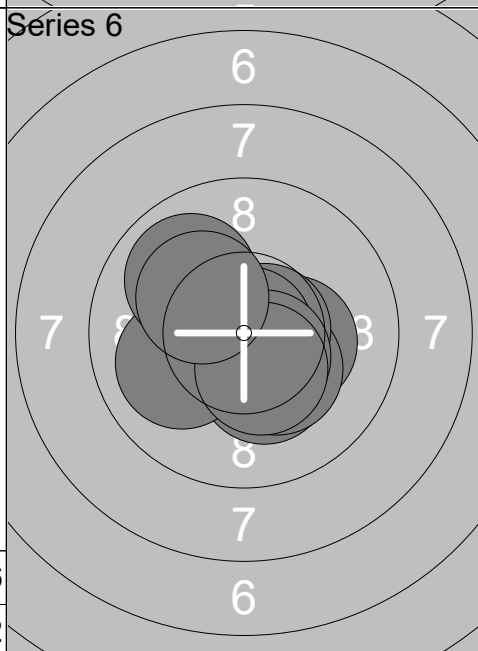

1:	10.3x	→
2:	10.3x	↘
3:	10.3x	↘
4:	10.6x	→
5:	10.9x	→
6:	10.5x	↘
7:	10.0	←
8:	10.4x	↘
9:	9.9	↗
10:	10.2x	↖
Series	103.4	
	614.6	

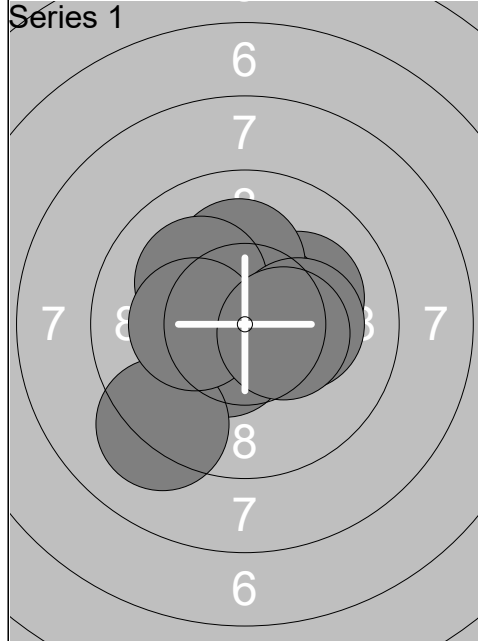

1:	10.5x ↙
2:	10.1 →
3:	10.3x ↖
4:	9.2 ↘
5:	10.6x ↗
6:	10.1 ↑
7:	10.1 ↖
8:	10.2x →
9:	10.3x ←
10:	10.4x →
Series	101.8
	101.8

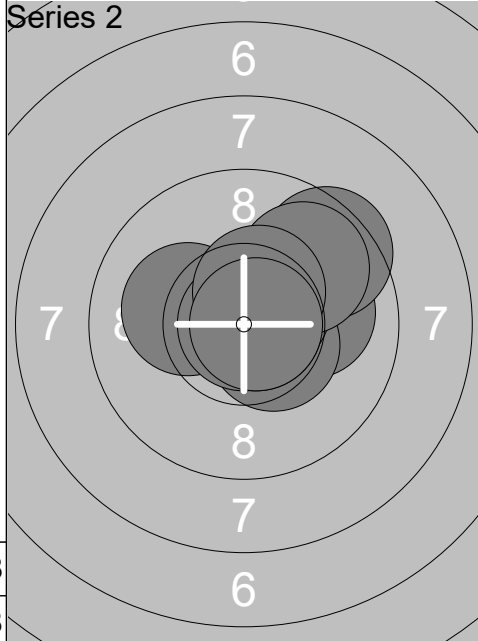

1:	10.0 →
2:	10.4x ↘
3:	10.8x →
4:	10.1 ←
5:	10.9x
6:	10.6x ↗
7:	9.4 ↗
8:	9.8 ↗
9:	10.5x ↗
10:	10.8x →
Series	103.3
	205.1

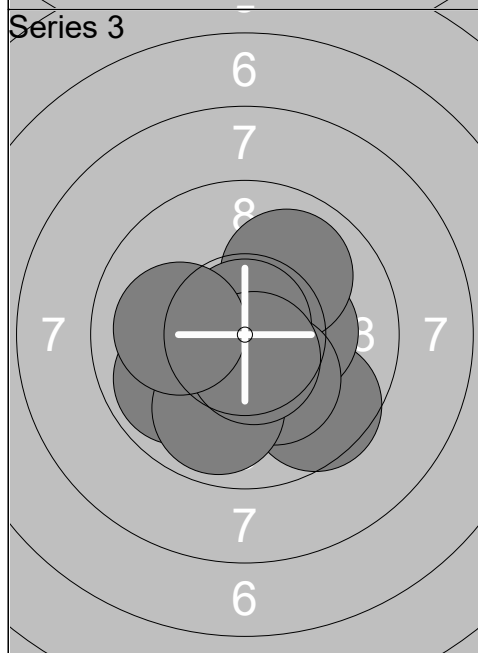

1:	10.2x ↙
2:	9.5 ↘
3:	10.3x →
4:	9.9 ↗
5:	10.2x ↘
6:	10.8x ↑
7:	9.8 ←
8:	9.9 ↘
9:	10.6x ↘
10:	10.1 ←
Series	101.3
	306.4

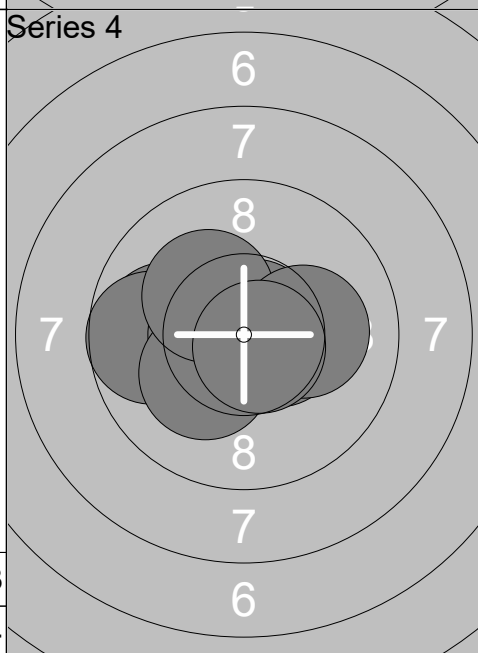

1:	10.8x ↗
2:	9.9 ←
3:	10.5x ←
4:	9.7 ←
5:	10.5x ←
6:	10.5x →
7:	10.2x ↙
8:	10.2x ↖
9:	10.1 →
10:	10.7x ↘
Series	103.1
	409.5

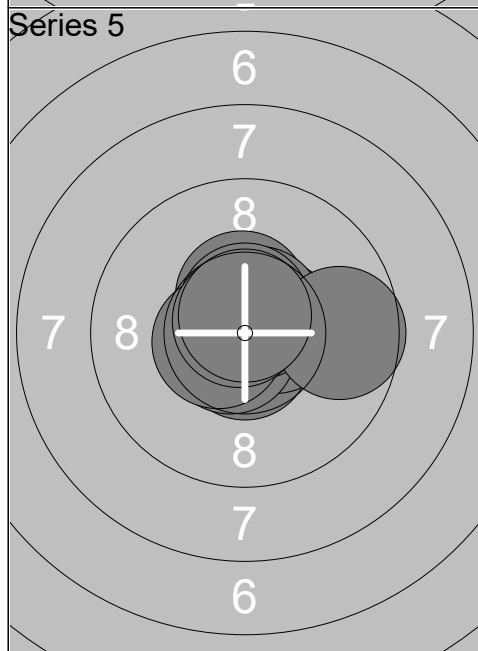

1:	10.7x ↓
2:	10.4x ↑
3:	10.5x →
4:	10.6x ↙
5:	10.6x ↗
6:	10.5x ←
7:	10.6x ↑
8:	9.6 →
9:	10.8x ↖
10:	10.7x ↑
Series	105.0
	514.5

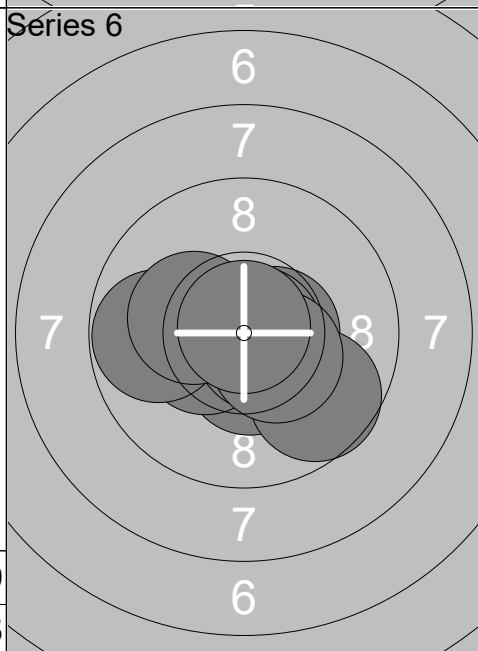

1:	10.5x →
2:	10.5x ↓
3:	9.6 ↘
4:	10.4x ←
5:	10.7x ↘
6:	10.8x →
7:	10.4x ↘
8:	9.8 ←
9:	10.2x ←
10:	10.9x ↑
Series	103.8
	618.3

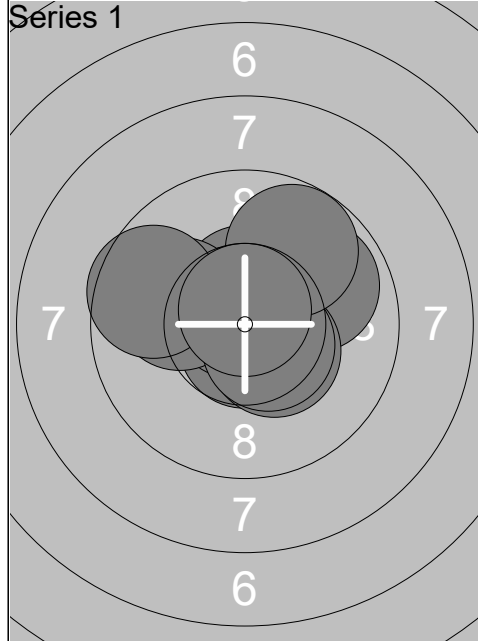

1:	10.5x ↑
2:	10.7x ↓
3:	9.9 ↗
4:	10.4x ↘
5:	10.8x ↖
6:	10.0 ←
7:	10.5x ↘
8:	9.7 ↗
9:	9.6 ←
10:	10.7x ↑
Series	102.8
	102.8

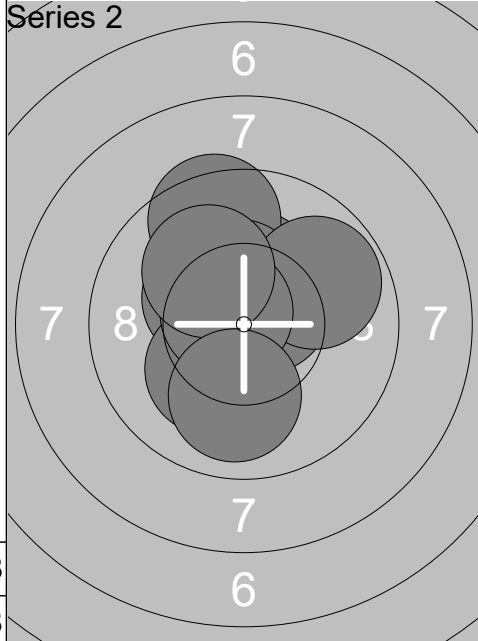

1:	10.3x ↑
2:	9.5 ↑
3:	10.6x ↗
4:	10.4x ↑
5:	10.3x ↖
6:	10.2x ↘
7:	9.8 ↗
8:	10.6x ↖
9:	10.1 ↖
10:	10.0 ↓
Series	101.8
	204.6

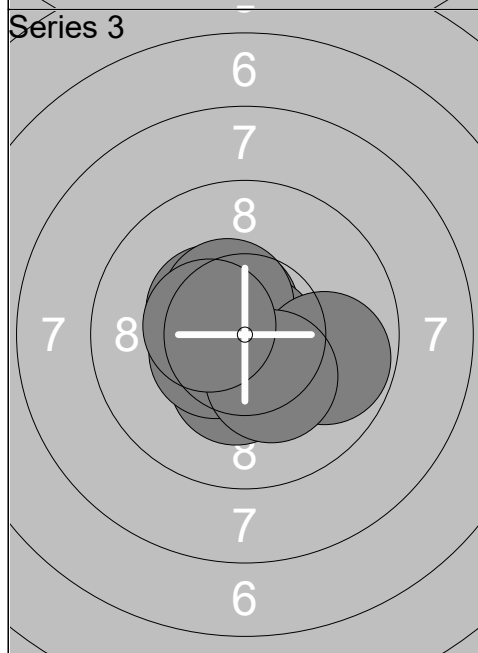

1:	10.6x ↖
2:	10.3x ↓
3:	10.5x ↙
4:	10.8x ↘
5:	10.4x ↖
6:	10.6x ↖
7:	10.5x ↖
8:	9.8 →
9:	10.3x ↓
10:	10.5x ↙
Series	104.3
	308.9

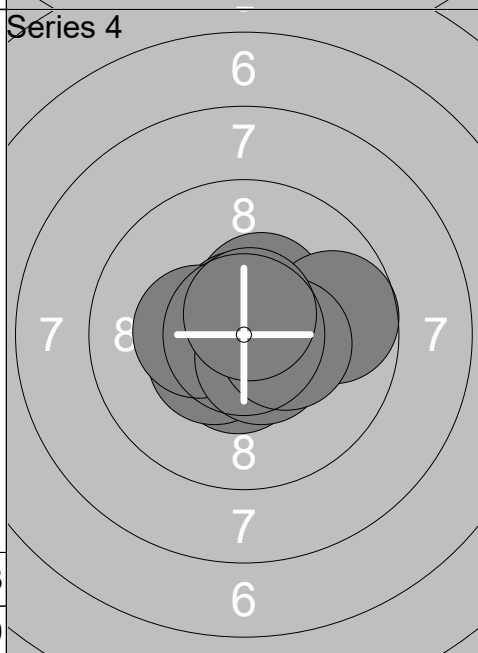

1:	10.5x ↓
2:	10.4x ↗
3:	10.7x ↑
4:	10.7x ↑
5:	10.4x ↙
6:	10.3x ↙
7:	10.5x ↘
8:	9.7 →
9:	10.4x →
10:	10.6x ↑
Series	104.2
	413.1

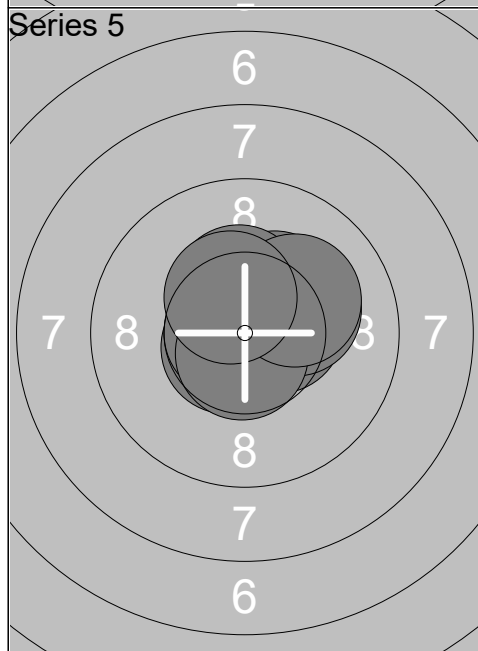

1:	10.6x ↙
2:	10.8x ↙
3:	10.3x ↗
4:	10.5x →
5:	10.3x ↑
6:	10.7x ↙
7:	10.2x ↗
8:	10.6x ↓
9:	10.1 ↗
10:	10.4x ↖
Series	104.5
	517.6

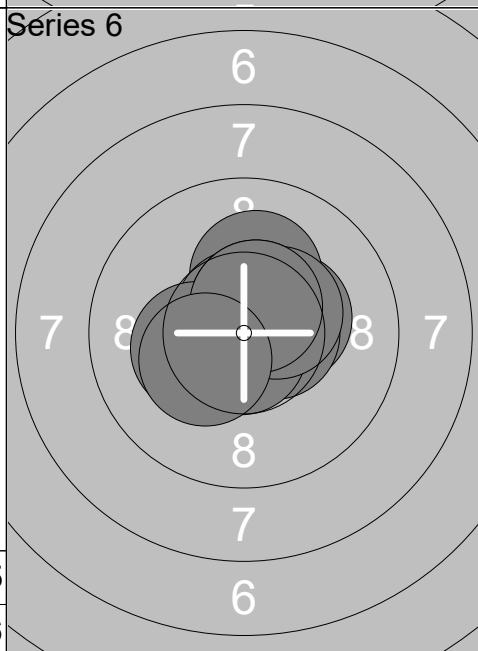

1:	10.3x →
2:	10.2x ↑
3:	10.7x ↑
4:	10.5x ↑
5:	10.5x →
6:	10.3x ↙
7:	10.7x ↓
8:	10.4x ↗
9:	10.5x ↑
10:	10.3x ↙
Series	104.4
	622.0

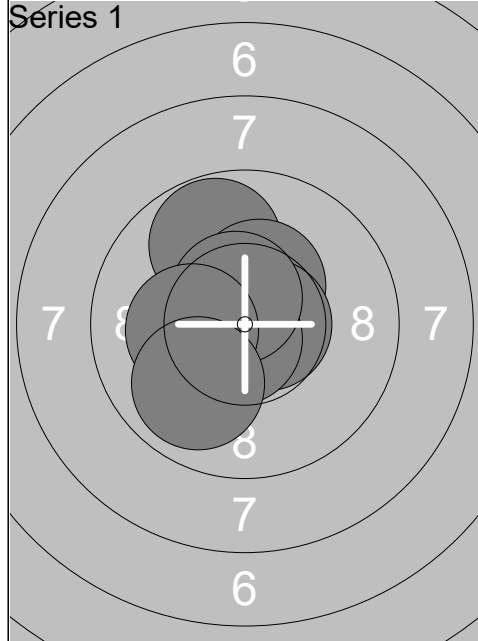

1:	10.4x ↑
2:	9.8 ↑
3:	10.7x ↑
4:	10.4x ↑
5:	10.7x →
6:	10.7x ←
7:	10.7x ↓
8:	10.6x ↑
9:	10.2x ←
10:	9.9 ↓
Series	104.1
	104.1

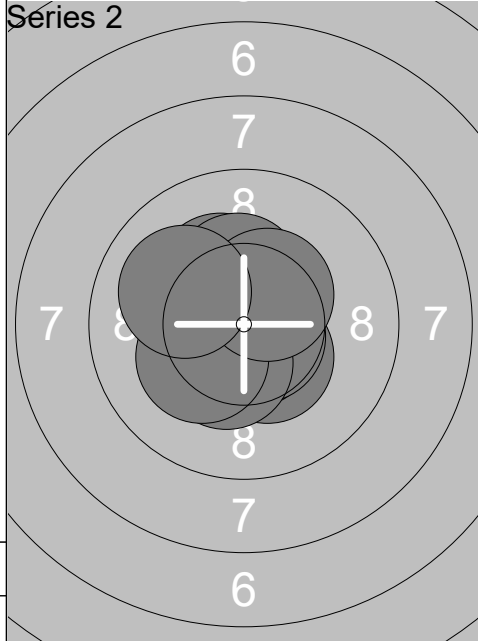

1:	10.4x ↓
2:	10.7x ↓
3:	10.3x ↗
4:	10.4x ↖
5:	10.7x ↘
6:	10.4x ↓
7:	10.2x ↙
8:	10.3x ↑
9:	10.4x ↗
10:	10.0 ←
Series	103.8
	207.9

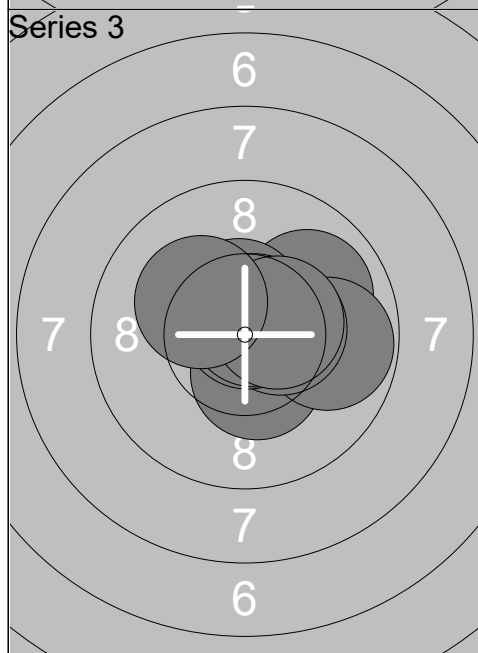

1:	9.9 ↗
2:	10.5x ↑
3:	10.8x ↘
4:	10.4x ↓
5:	9.8 →
6:	10.5x →
7:	10.8x ↑
8:	10.7x ↗
9:	10.5x →
10:	10.2x ↖
Series	104.1
	312.0

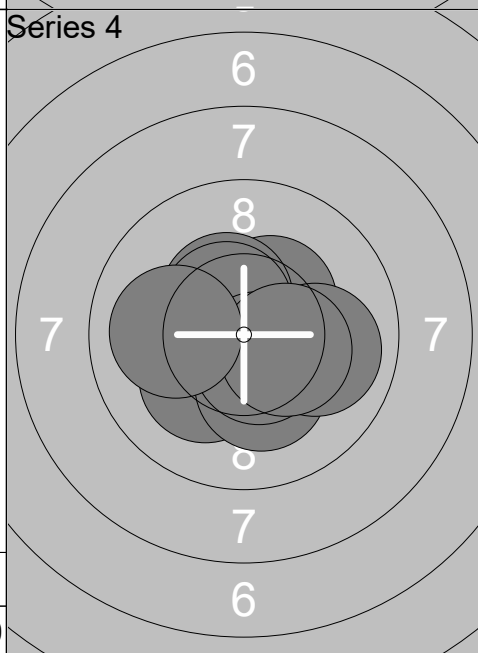

1:	10.4x ↗
2:	10.4x ↖
3:	10.8x ↖
4:	10.2x ↙
5:	10.5x ↖
6:	10.2x ↓
7:	10.6x ↓
8:	10.0 →
9:	10.3x →
10:	10.0 ←
Series	103.4
	415.4

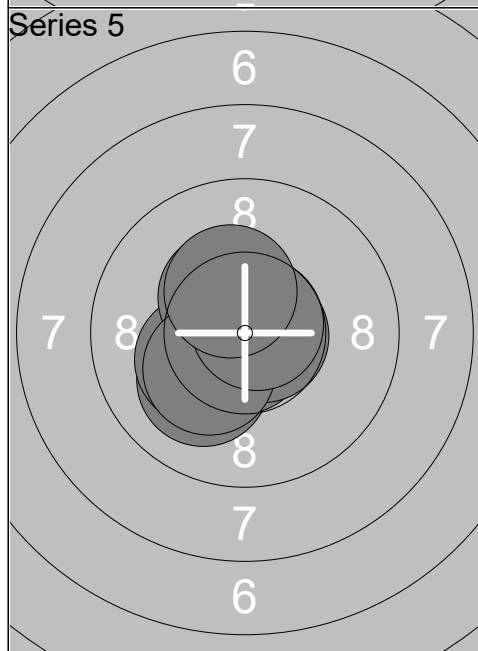

1:	10.1 ↓
2:	10.9x ↓
3:	10.7x ↓
4:	10.7x →
5:	10.7x ↖
6:	10.2x ↙
7:	10.4x ↖
8:	10.2x ↙
9:	10.7x ↗
10:	10.3x ↑
Series	104.9
	520.3

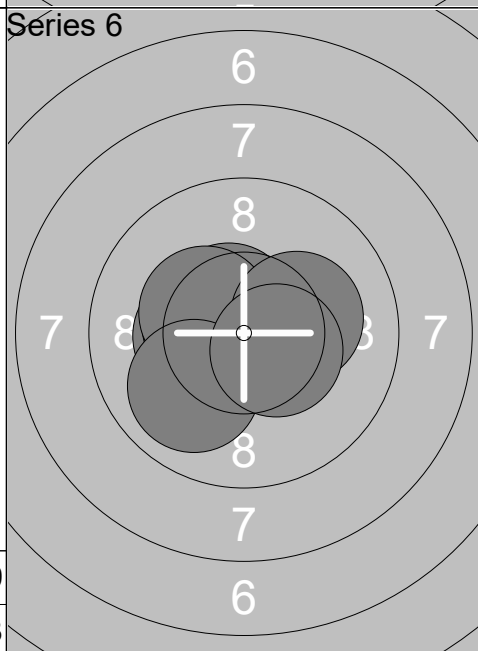

1:	10.6x ↙
2:	10.3x ←
3:	10.4x ↙
4:	10.6x →
5:	10.6x ↖
6:	10.4x ↙
7:	10.3x ↙
8:	9.9 ↓
9:	10.2x →
10:	10.4x →
Series	103.7
	624.0

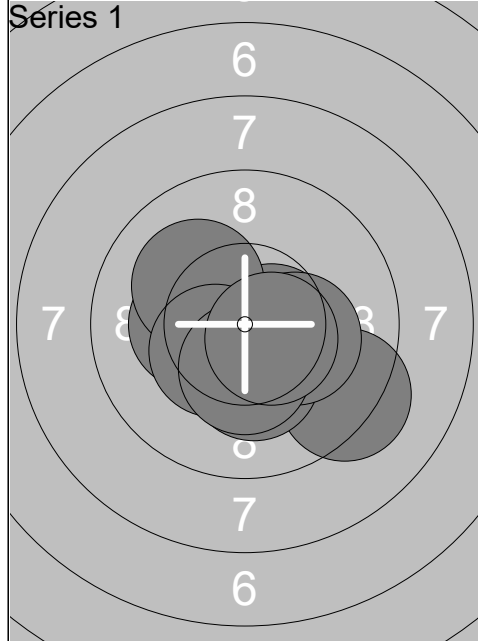

1:	10.6x →
2:	9.9 ↘
3:	9.3 ↘
4:	10.2x ↓
5:	10.2x →
6:	10.2x ←
7:	10.1 ↖
8:	10.4x ↙
9:	10.3x ↓
10:	10.5x →
Series	101.7
	101.7

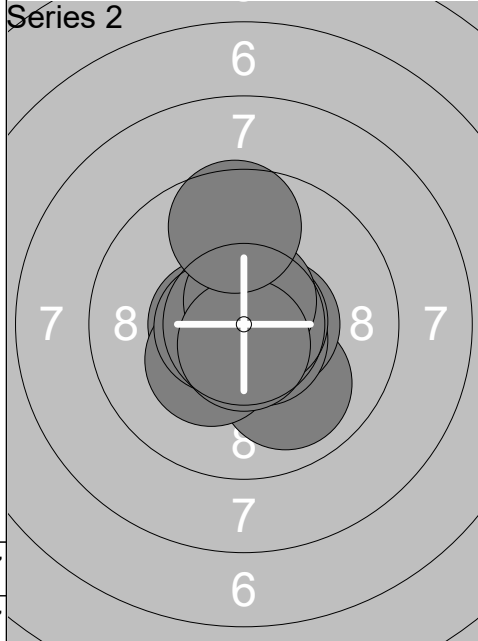

1:	9.9 ↘
2:	10.5x →
3:	10.6x ↘
4:	10.5x ←
5:	10.3x ↙
6:	10.7x →
7:	10.6x ←
8:	10.6x ↑
9:	10.6x ↓
10:	9.6 ↑
Series	103.9
	205.6

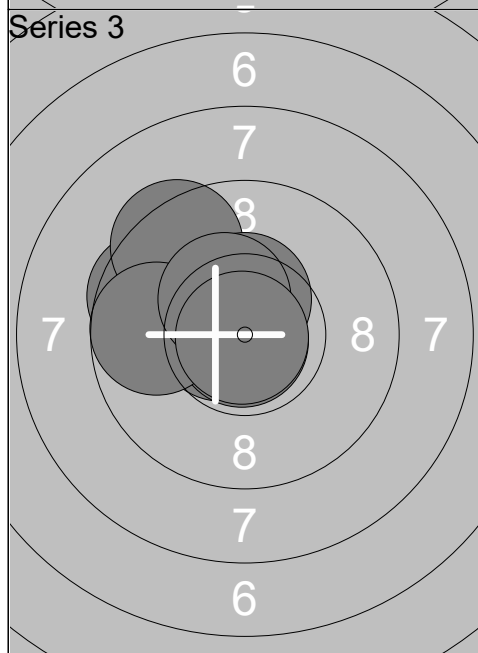

1:	10.7x ↖
2:	9.6 ←
3:	10.4x ←
4:	10.6x ←
5:	10.8x ↙
6:	9.4 ↖
7:	10.4x ↑
8:	9.7 ←
9:	10.4x ↖
10:	10.9x ↙
Series	102.9
	308.5

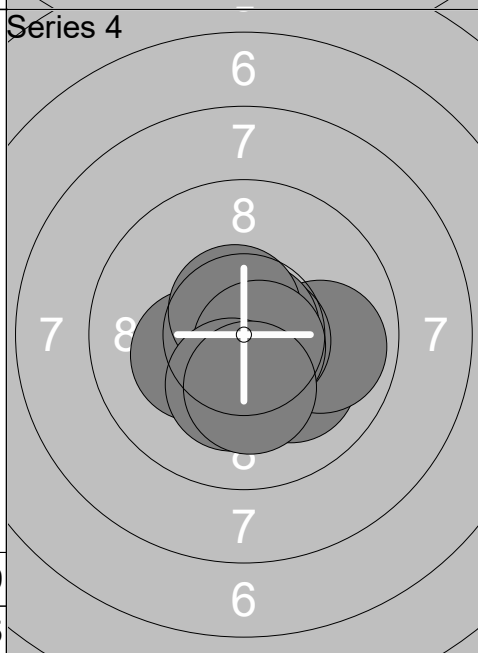

1:	10.1 ↘
2:	9.9 →
3:	10.7x →
4:	10.2x ←
5:	10.6x →
6:	10.8x ↗
7:	10.6x ↑
8:	10.7x ↘
9:	10.2x ↓
10:	10.2x ↓
Series	104.0
	412.5

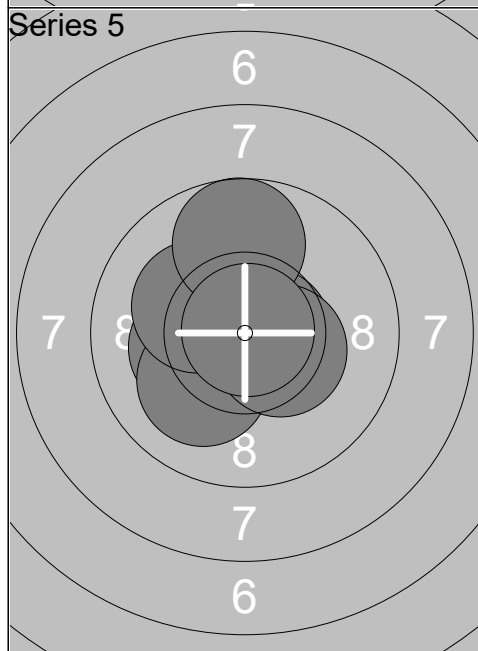

1:	10.7x ↘
2:	10.9x ←
3:	10.3x ←
4:	10.7x →
5:	10.2x ←
6:	10.1 ↘
7:	10.2x ↖
8:	9.7 ↑
9:	10.4x →
10:	10.9x ↗
Series	104.1
	516.6

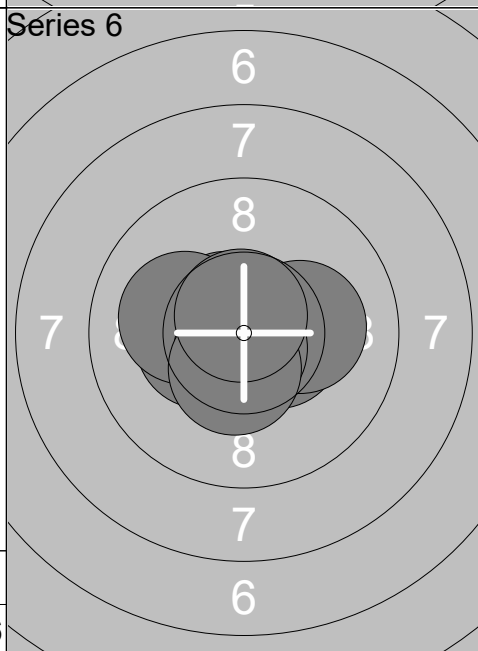

1:	10.6x ↖
2:	10.4x ←
3:	10.4x ←
4:	10.5x →
5:	10.6x ←
6:	10.1 ←
7:	10.1 →
8:	10.7x ↓
9:	10.4x ↓
10:	10.7x ↑
Series	104.5
	621.1

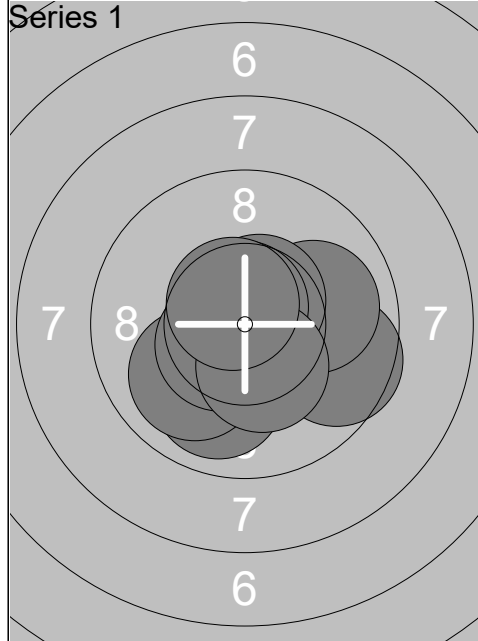

1:	9.6	➔
2:	10.0	➔
3:	9.9	⬇
4:	10.0	⬇
5:	10.8x	⬇
6:	10.5x	↗
7:	10.7x	↑
8:	10.5x	↙
9:	10.3x	⬇
10:	10.6x	↖
Series		102.9
		102.9

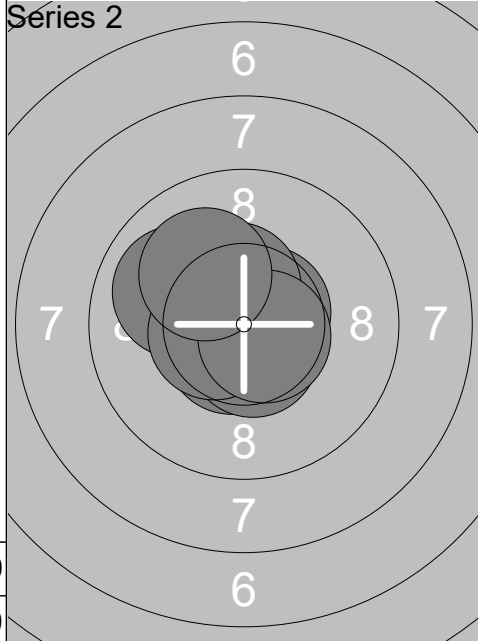

1:	10.4x	↙
2:	10.6x	↗
3:	10.9x	↑
4:	9.9	↖
5:	10.4x	↑
6:	10.6x	⬇
7:	10.6x	⬇
8:	10.5x	↙
9:	10.6x	➔
10:	10.1	↖
Series		104.6
		207.5

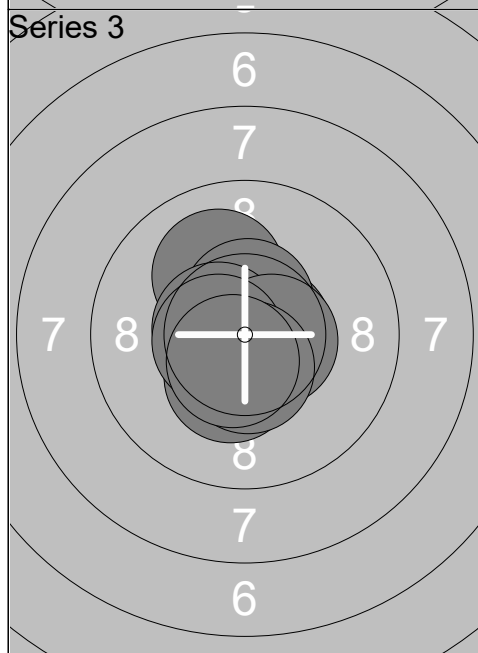

1:	10.7x	➔
2:	10.0	↖
3:	10.5x	↑
4:	10.7x	↙
5:	10.3x	⬇
6:	10.6x	↙
7:	10.6x	➔
8:	10.5x	↙
9:	10.5x	⬇
10:	10.5x	⬇
Series		104.9
		312.4

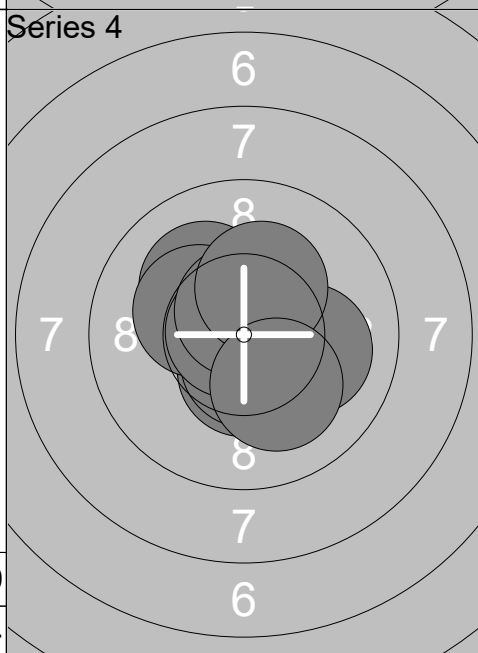

1:	10.1	↖
2:	10.6x	⬇
3:	10.5x	⬇
4:	10.3x	↙
5:	10.6x	⬇
6:	10.1	➔
7:	10.8x	↙
8:	10.6x	↑
9:	10.2x	↑
10:	10.1	⬇
Series		103.9
		416.3

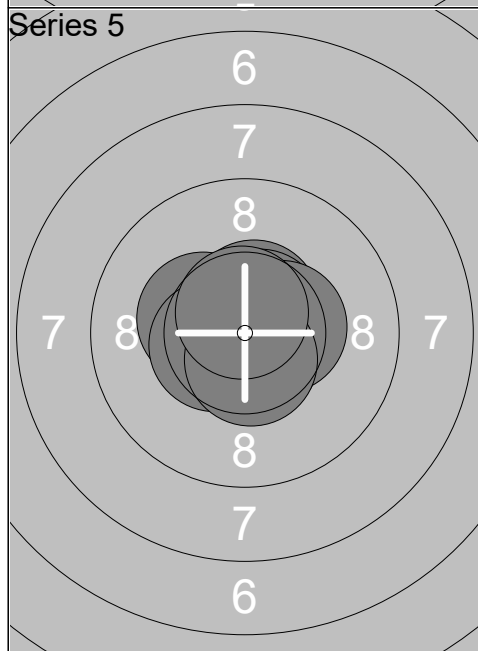

1:	10.7x	⬇
2:	10.3x	↙
3:	10.8x	⬇
4:	10.5x	↑
5:	10.6x	⬇
6:	10.6x	↗
7:	10.5x	↙
8:	10.4x	➔
9:	10.5x	⬇
10:	10.6x	↑
Series		105.5
		521.8

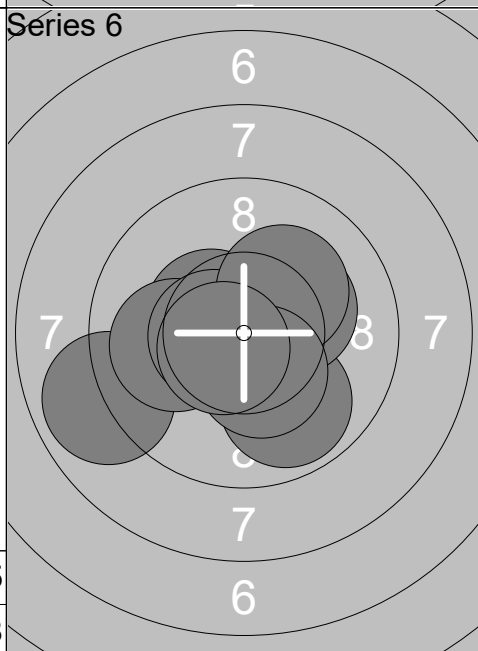

1:	10.5x	↙
2:	8.9	↙
3:	10.4x	↙
4:	9.8	⬇
5:	10.2x	↗
6:	10.0	↖
7:	10.5x	↙
8:	10.2x	↗
9:	10.4x	⬇
10:	10.6x	↙
Series		101.5
		623.3

Relay	Lane	Brian Baudouin		
1 Air Qualification	FRA	M		
19.02.2023	DENMARK OPEN AIR 2023 DAY3	Danmark Open Air 2023		
Series 1	1: 10.4x ← 2: 10.4x ↗ 3: 10.4x ↖ 4: 10.7x → 5: 10.3x ↑ 6: 10.1 ↑ 7: 10.7x ↙ 8: 10.7x ↘ 9: 10.6x ↑ 10: 10.7x ↘ Series 105.0 105.0	Series 2	1: 10.5x ↓ 2: 10.6x ↗ 3: 10.4x ← 4: 10.8x ↙ 5: 10.8x ↓ 6: 10.8x ← 7: 10.6x ↓ 8: 10.4x ↘ 9: 10.8x ↗ 10: 10.7x ← Series 106.4 211.4	
Series 3	1: 10.3x ↖ 2: 10.7x ↑ 3: 10.8x → 4: 10.6x ↙ 5: 10.2x ↗ 6: 10.4x ↙ 7: 10.7x ↘ 8: 10.5x ↓ 9: 10.0 → 10: 9.6 ← Series 103.8 315.2	Series 4	1: 10.8x ↓ 2: 10.6x ↓ 3: 10.4x ← 4: 10.3x ↗ 5: 10.9x 6: 10.1 ↑ 7: 10.4x ↗ 8: 9.8 ← 9: 10.5x ↗ 10: 10.2x → Series 104.0 419.2	
Series 5	1: 10.7x ↑ 2: 10.5x ↗ 3: 10.8x ↗ 4: 10.0 ↑ 5: 10.4x ↗ 6: 10.4x ↗ 7: 10.7x ↖ 8: 10.4x → 9: 10.4x → 10: 10.6x ↘ Series 104.9 524.1	Series 6	1: 10.5x ↓ 2: 10.3x → 3: 10.8x ↑ 4: 10.0 → 5: 10.5x → 6: 10.1 ↘ 7: 10.5x ↗ 8: 9.8 → 9: 10.7x → 10: 10.8x ↗ Series 104.0 628.1	

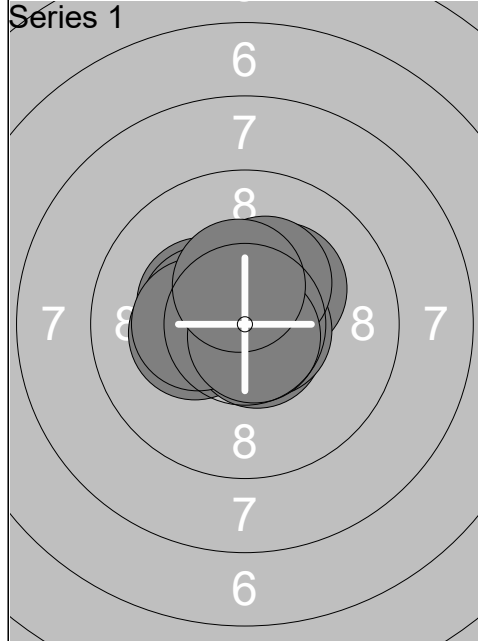

1:	10.3x ↖
2:	10.3x ↗
3:	10.4x ↖
4:	10.2x ↖
5:	10.7x ↘
6:	10.3x ↖
7:	10.6x →
8:	10.3x ↗
9:	10.7x ↘
10:	10.4x ↑
Series	104.2
	104.2

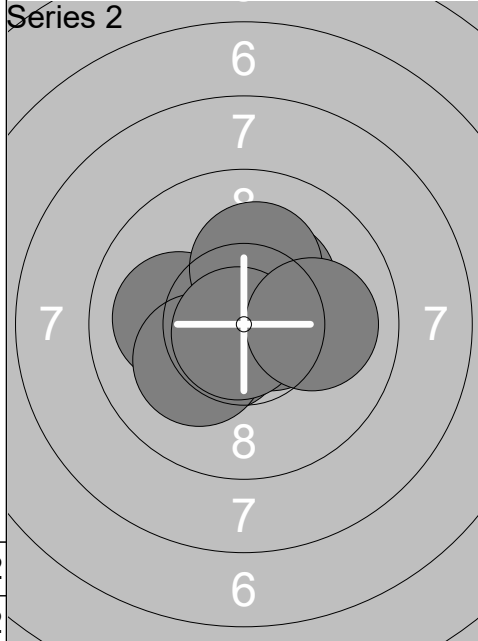

1:	10.2x ↘
2:	10.5x ↘
3:	10.1 ←
4:	10.3x ↗
5:	10.6x →
6:	10.7x ↗
7:	10.2x ↘
8:	10.1 ↑
9:	10.8x ↘
10:	10.0 →
Series	103.5
	207.7

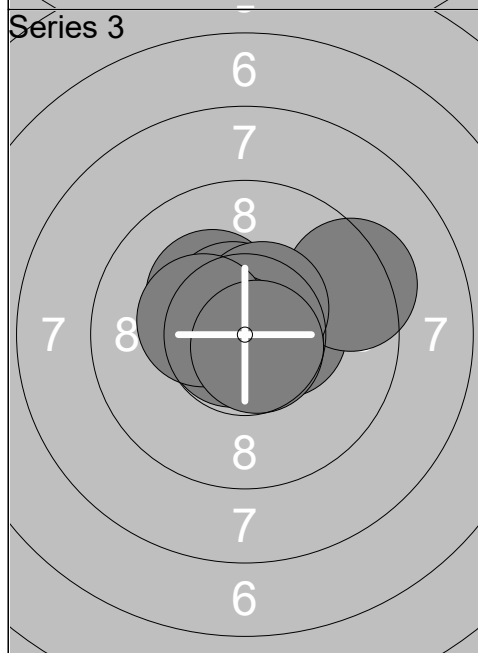

1:	10.7x ↖
2:	10.5x →
3:	9.3 ↗
4:	10.3x ↖
5:	10.7x ↘
6:	10.5x ↗
7:	10.5x ↗
8:	10.8x ↖
9:	10.3x ↖
10:	10.7x ↘
Series	104.3
	312.0

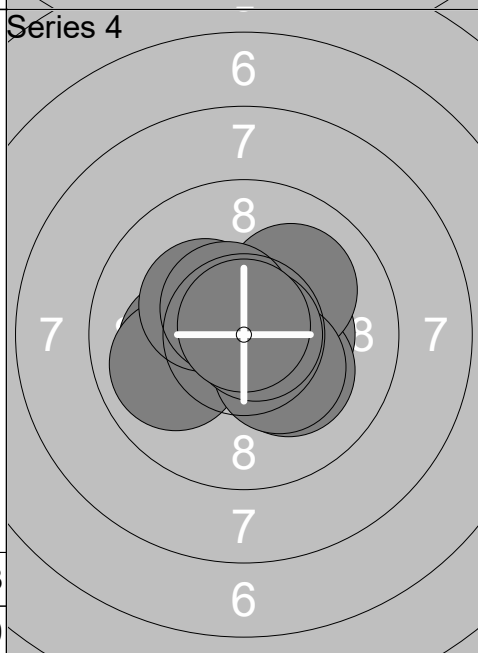

1:	10.1 ←
2:	10.3x →
3:	10.2x ↘
4:	9.9 ←
5:	10.1 ↗
6:	10.3x ↘
7:	10.8x →
8:	10.3x ↖
9:	10.5x ↖
10:	10.8x ↑
Series	103.3
	415.3

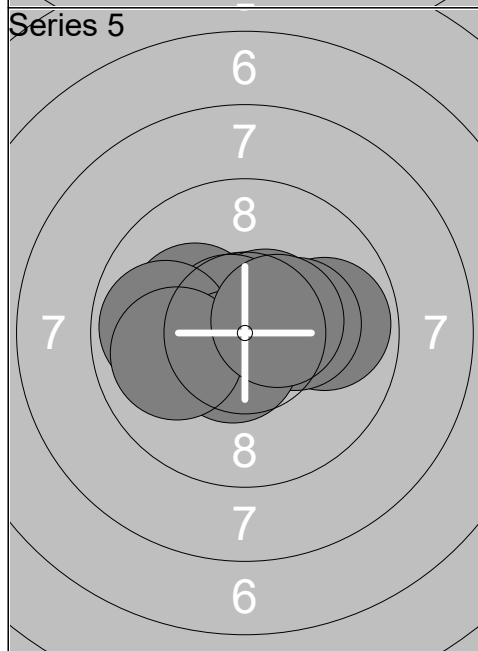

1:	10.7x ↑
2:	9.8 →
3:	10.2x ↖
4:	10.5x ↗
5:	10.7x ↖
6:	9.8 ←
7:	10.3x →
8:	10.6x ↘
9:	10.0 ←
10:	10.5x →
Series	103.1
	518.4

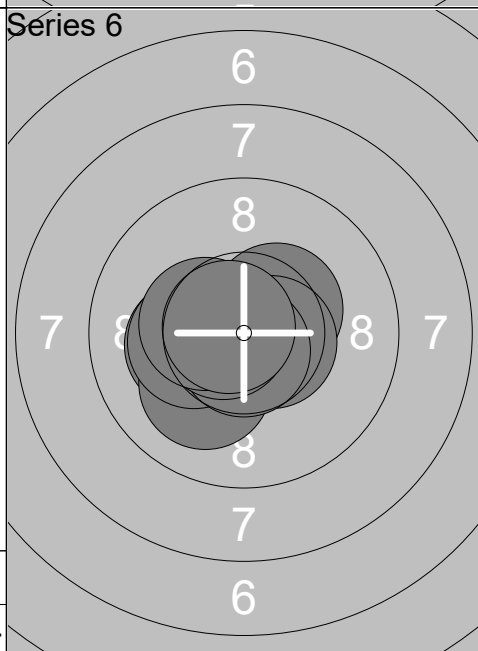

1:	10.5x ↘
2:	10.4x ↗
3:	10.2x ↖
4:	10.1 ↘
5:	10.2x ↖
6:	10.6x →
7:	10.7x ↘
8:	10.7x ↖
9:	10.4x ↖
10:	10.7x ↖
Series	104.5
	622.9